

# Service Bulletin

**Subject:** Releasing New McDonald's Next Generation Electric Grills  
**To:** Authorized Service Agencies, US & Canada  
**Product:** ME-1P, ME-2P, ME-3PX Electric Models  
**Date:** June 5, 2017

Garland is launching the new, next generation 1, 2 & 3 platens electric grills for McDonald's. The next generation grills are designed with a new common Clamshell Platform. To support the up-coming product launch, we are inviting our Authorized Service partners to participate in the service roll-out program for the new grills.

## 1. Parts Support

- 1A. Please find on p.3, a list of critical and recommended parts that agencies must stock in order to provide fast and quality service support.
- 1B. Ensure parts availability, and carry the Go Box parts in the service truck on service calls.
- 1C. Some of the parts may already be in your inventory. Review the stock parts list for more details.

## 2. Manual downloads

(From Garland McDonald's Portal)



- 2A. Installation operation manual, [click here](#)

**McDonald's next Generation ME and MG Grill Installation Operation Manual**

- [\(English\) Installation/Operation Manual](#)
- [\(French\) Installation/Operation Manual](#)
- [\(German\) Installation/Operation Manual](#)
- [\(Japanese\) Installation/Operation Manual](#)
- [\(Polish\) Installation/Operation Manual](#)
- [\(Russian\) Installation/Operation Manual](#)

- 2B. Part list, [click here](#)

**McDonald's next Generation ME and MG Grill Part List Manual**

- [GAR\\_P\\_4602410.pdf](#)

- 2C. Service manual: [click here](#)

## 3. QR Code

- 3A.  Manuals can also be viewed/downloaded on your mobile device by scanning the QR Code that is affixed onto grill's front panel, lower right.



## 4. New Grill Start-Up

- 4A. Current dispatch process applies.
- 4B. Must complete Start-Up Form for all newly installed grills.
- 4C. Current grill start-up fees and program are applicable.
- 4D. Every new grill will have a start-up form included.
- 4E. (USA only) E-mail the completed Start-Up Form to RISE at: [rise.callcenter@welbilt.com](mailto:rise.callcenter@welbilt.com)
- 4F. Attach the completed Start-Up Form to warranty claim on ServiceBench Warranty System.

## 5. Training

- 5A. New grill training is incorporated into current in-class grill trainings. However, every FAS and Branch location is required to have at least one trained technician before the roll-out. ASAP, please use the on-line training module.
- 5B. The on-line training is available to Garland FAS Technicians, and current In-house technicians who have a password and log-in for Garland McDonald's Portal.

- 5C. To access on-line training via Garland McDonald's Portal:

- For Garland FAS tech, obtain password and log in from your administrator or manager.
- On the Garland McDonald's Portal ([click here](#)), log in via



- Select at top, [Literature & Documentation](#)
- Scroll down to the on-line training link:

**McDonald's next Generation ME and MG Grill Training.**

- [ME and MG Grill on-line training](#)

- Click on the on-line training link and then follow instructions on screen to complete an on-line form. Please ensure you fill out all fields correctly to get credit for the training. A confirmation email will be sent to you with additional information for accessing the on-line training.
  - When the on-line course is completed, must email your result page to [robert.gray@welbilt.com](mailto:robert.gray@welbilt.com) for an acknowledgment of completion. (Use Copy/Paste or Print Screen option on your device and paste in an email.)
- 5D. Contact your Garland Field Service Manager for more information.

## 6. Service Support

- 6A. All service call requests for McDonald's Garland Next Generation Grills must be reported to our US & Canada Technical Support Call Center (844-724-2273) before the dispatch of a service technician. The purpose of this process is to gather information, provide technical support and possibly assist with service call prevention on behalf of the Store location. If a service call is required, the Service Technician or FAS must call into Garland's Technical support call center after the service call is completed. The grill's serial number will be required. Garland will provide an Event Number at that time (after the service call is completed) that will be used to track history of the clamshell grills in the field.
- 6B. The Garland Event Number (Contract Number) must be submitted on a warranty claim, otherwise the claim will be rejected.
- 6C. In the situation when the service call request is on weekends, holidays or not between 8AM to 5PM (EST), obtain an Event Number (Contract Number) from technical support call center on the next business day.

## 7. Warranty

- 7A. Standard two years parts and labor warranty applies to units.
- 7B. Standard 90 Days Replacement Parts warranty policy is applicable.

## Model Numbers

**Note: Only electric (E) models are released at this point.**

M(E/G)1P : 1 platen grill.

M(E/G)2P : 2 platen grill.

M(E/G)3PX : 2 + 1 platen, single chassis grill.

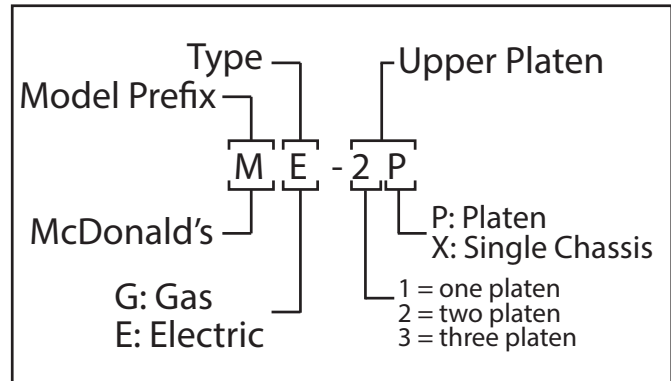

M(E/G)-1P



M(E/G)-2P



M(E/G)-3PX

### McDonald's Electric Grill Critical GoBox and Recommended Stock Parts List

A	B	C	D	E	F	G	H	I	J
Part Number	Description	Critical GoBox	Recommended Agency Stock	Service Agency Stock 1-5 Grills	Service Agency Stock Over 6 Grills	New Part #	Existing Part #	Common Parts for New Clamshell Platform	MCDS Electric (ME)
1									
2	1859605	PUSH BUTTON GREEN	X		1	2		X	X
3	1859606	CONTACT BLOCK	X		1	2		X	X
4	1859607	MOUNTING LATCH	X		1	2		X	X
5	4523482	SPEAKER	X		1	1		X	X
6	4531930	MICROSWITCH OVERTRAVEL	X		2	3		X	X
7	4531977	THERMOSTAT SPST	X		2	3		X	X
8	4532394	SHAFT SEAL	X		2	3	X		X
9	4600100	PLATEN THERMOCOUPLE	X		2	3	X		X
10	4600101	GRILL PLATE THERMOCOUPLE ELECTRIC	X		1	2	X		X
11	4600128	MOTOR - 24VDC LEVELLING	X		1	2	X		X
12	4600170	ACTUATOR ASSY	X		1	3	X		X
13	4600481	SEAL, PLATEN ARM TO COVER	X		1	2	X		X
14	4600605	O RING	X		2	3	X		X
15	4600614	MAIN POWER SWITCH	X		2	4	X		X
16	4600616	LIMIT SWITCH	X		2	3	X		X
17	4600637	FUSE 6.3A CE ONLY	X		2	2	X		X
18	4600638	FUSE 10A UL ONLY	X		2	4	X		X
19	4531775-9	SSRB HEATSINK ASSY.	X		1	2	X		X
20	CK4601735	HRCB+ USER INTERFACE ASSEMBLY	X		1	2	X		X
21	CK4601832	SIB & MOUNT PLATE ASSEMBLY	X		1	2	X		X
22	4600613	26 PIN RIBBON CABLE	X		1	1	X		X
23	4600722	TEFLON REAR LOOP HANGER	X		2	4	X		X
24	1637001	CONTACTOR 120V		X	1	1		X	X
25	1637002	CONTACTOR 240V		X	1	1		X	X
26	2213012	WASHER #8 SS		X	6	6		X	X
27	4527294	TEFLON SHEET CLIP		X	4	6		X	X
28	4531933	DIODE 15A		X	1	1		X	X
29	4532040	USB PANEL MOUNT ASSY WITH LOCK NUT		X	1	1		X	X
30	4532382	CIRCUIT BREAKER 60A 3 PLATEN		X	1	1	X		X
31	4532393	SEAL CAP		X	1	1		X	X
32	4532675	FRONT CASTER		X	1	1	X		X
33	4532676	REAR CASTER		X	1	1	X		X
34	4532744	COWL GASKET		X	1	1	X		X
35	4532752	FLANGE BEARING		X	4	4	X		X
36	4600124	CIRCUIT BREAKER 32A 2 PLATEN		X	1	1	X		X
37	4600125	CIRCUIT BREAKER 25A 1 PLATEN		X	1	1	X		X
38	4600127	Sensor - Inductive Proximity PWM		X	2	2	X		X
39	4600290	TEFLON SHEET - McDonald's		X	2	4	X		X
40	4600630	CIRCUIT BREAKER 40A		X	1	1	X		X
41	4600646	SENSOR TARGET		X	1	2	X		X
42	4600725	PLATEN CONDUIT C/W WIRE HARNESS		X	1	1	X		X
43	4600838	POWER SUPPLY 24V		X	1	2	X		X
44	4601675	EMC FILTER 3 PHASE (CE models)		X	1	2	X		X
45	4601719	POWER INLET LINE FILTER (CE models)		X	1	2	X		X
46	4532043-GAR	USB CAP		X	1	1		X	X
47	CK4600396	PLATEN - COWL ASSEMBLY WG c/w conduit		X	1	1	X		X
48	CK4600590	U-BAR REAR HOLDER ASSEMBLY		X	2	2	X		X
49	CK4600591	U-BAR FRONT HOLDER ASSEMBLY		X	2	2	X		X
50	F801	SCREW-#8-32X3/4L 18-8 TRIM HX HD M/S		X	6	6		X	X

Note:  
 Critical GoBox Parts: Columns C and E/ F  
 Comparing New and Existing Part Numbers: Columns G, H.