



1-Platen Gas Clamshell Grill w/Product Recognition

1-Platen Gas Clamshell Grill w/Product Recognition

Model: MWG1W

Product Features:



- Product Recognition technology that automatically senses the food product placed on the grill yields faster, flexible operation and reduces waste.
- Proven one-platen design with auto-calibration of platen for gapping precision, consistent product quality and expanded self diagnostics.
- LonWorks® technology to network the grill into the “kitchen of the future,” reducing energy consumption and increasing operational efficiency.
- No access of upper platen required for adjustments and simple motorized movement of upper platen minimizes components.
- Dual temperature sensors per gas heat zone provides for maximum temperature control.
- Two year parts and labor warranty.

The Garland Clamshell grill, manufactured exclusively for McDonald's, provides a method for efficient two-sided cooking, while accommodating a variety of products. This grill meets all of McDonald's standards for safety, efficiency, and cleanliness.



The specifications on this sheet are for the exclusive use of licensees of the McDonald's Corporation.

Manufactured Exclusively for McDonald's by:
Garland Commercial Ranges Ltd.
1177 Kamato Road, Mississauga ON L4W 1X4
Phone: (905) 624-0260 • Fax: (905) 624-1851 • Toll Free: (800) 427-6668





1-Platen Gas Clamshell Grill w/Product Recognition

1-Platen Gas Clamshell Grill w/Product Recognition

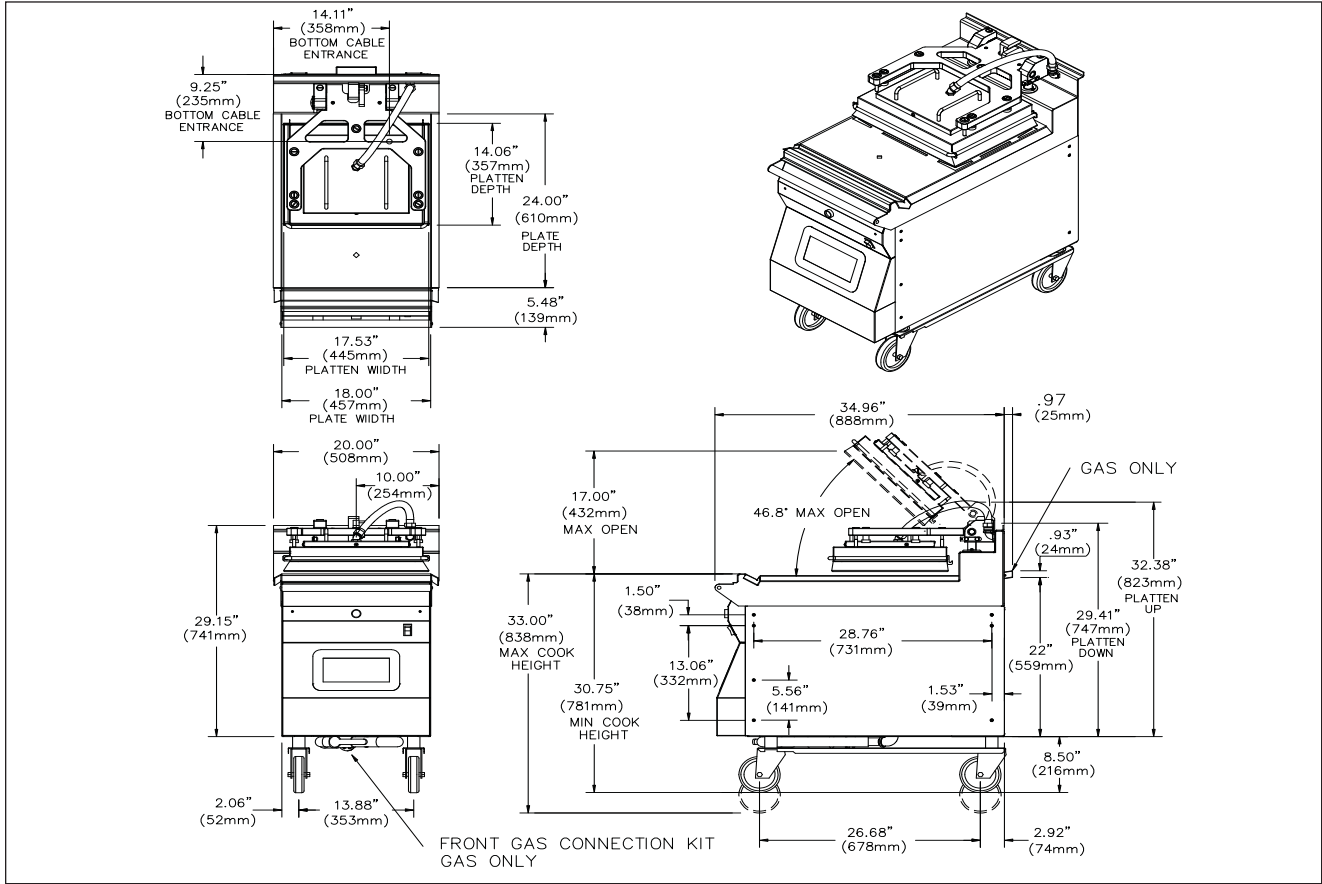

Input Specifications, GAS SINGLE PLATEN MWG1W Grills, North America										
SUPPLY	TOTAL kW LOAD	NOMINAL AMPS PER LINE								
		208V / 60 Hz			220V / 60 Hz			240V / 60 Hz		
		L1	L2	L3	L1	L2	L3	L1	L2	L3
INPUT 1	5.6	15.6	15.6	15.5	14.7	14.7	14.7	13.5	13.5	13.5
GAS INPUT		MAX INPUT (NET) PER BURNER (BTU/H)		TOTAL INPUT RATING (BTU/H)		SUPPLY PRESSURE (IN W.C.)		BURNER MANIFOLD PRESSURE (IN W.C.)		
NATURAL GAS		32,000		32,000		7.0		3.5		
PROPANE		32,000		32,000		11.0		10.0		

Input Specifications, GAS SINGLE PLATEN MWG1W Grills, CE Approved Model													
SUPPLY	TOTAL kW LOAD	LOADING: (kW/PHASE)			NOMINAL AMPS PER LINE								
		380V/ 400V/ 415V			380V			400V			415V		
		L1/N	L2/N	L3/N	L1	L2	L3	L1	L2	L3	L1	L2	L3
INPUT 1	5.7	1.8	1.8	1.9	8.5	8.5	8.9	8.1	8.1	8.5	7.8	7.8	8.2
GAS GROUP		MAX INPUT (NET) PER BURNER (kW)		TOTAL INPUT RATING (kW)		SUPPLY PRESSURE (mbar)		BURNER PRESSURE (mbar)		VOLUMETRIC GAS RATE			
G20 NG		8.6		8.6		20/25		8.7		0.91 m ³ /h			
G31 LPG		8.6		8.6		37/50		24.9		0.67 kg/h			

The specifications on this sheet are for the exclusive use of licensees of the McDonald's Corporation.

Manufactured Exclusively for McDonald's by:
Garland Commercial Ranges Ltd
1177 Kamato Road, Mississauga ON L4W 1X4
Phone: (905) 624-0260 • Fax: (905) 624-1851 • Toll Free (800) 427-6668



Form# MWG1W (16 Jan 12)