



1-Platen Electric Clamshell Grill w/Product Recognition

1-Platen Electric Clamshell Grill w/Product Recognition

Model: MWE1W



Product Features:

- Product Recognition technology that automatically senses the food product placed on the grill yields faster, flexible operation and reduces waste.
- Proven one-platen design with auto-calibration of platen for gapping precision, consistent product quality and expanded self diagnostics.
- LonWorks® technology to network the grill into the “kitchen of the future,” reducing energy consumption and increasing operational efficiency.
- No access of upper platen required for adjustments and simple motorized movement of upper platen minimizes components.
- Two year parts and labor warranty.

The Garland Clamshell grill, manufactured exclusively for McDonald's, provides a method for efficient two-sided cooking, while accommodating a variety of products. This grill meets all of McDonald's standards for safety, efficiency, and cleanliness.



The specifications on this sheet are for the exclusive use of licensees of the McDonald's Corporation.

Manufactured Exclusively for McDonald's by:
Garland Commercial Ranges Ltd.
1177 Kamato Road, Mississauga ON L4W 1X4
Phone: (905) 624-0260 • Fax: (905) 624-1851 • Toll Free: (800) 427-6668





1-Platen Electric Clamshell Grill w/Product Recognition

1-Platen Electric Clamshell Grill w/Product Recognition

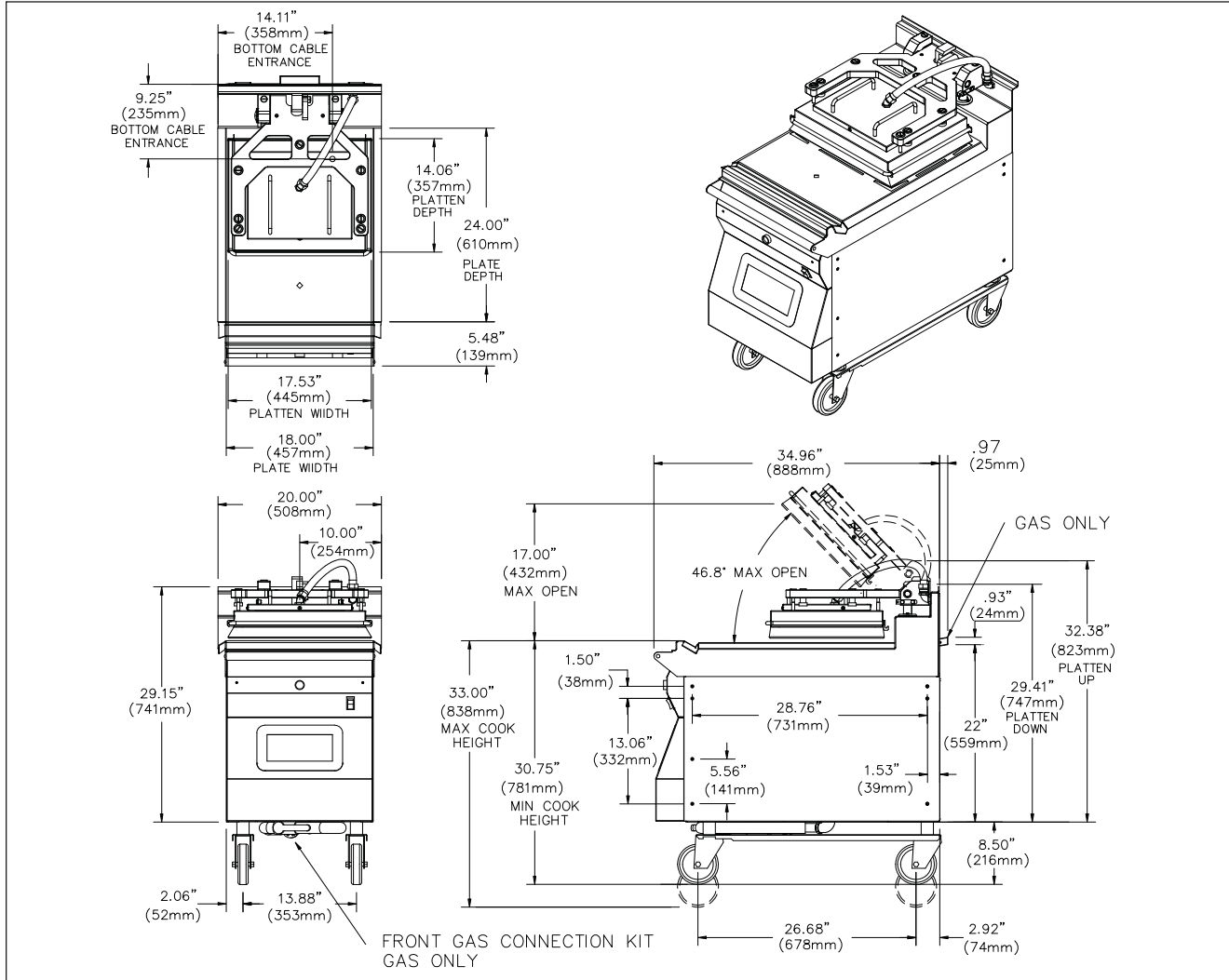

Input Specifications, MWE1W, for North America

CONNECTION	SUPPLY REQUIRED	TOTAL KW LOAD	NOMINAL AMPS PER LINE								
			208V			220V			240V		
			L1	L2	L3	L1	L2	L3	L1	L2	L3
SINGLE	INPUT 1	10.6	29.5	29.5	29.5	27.9	27.9	27.9	25.5	25.5	25.5

Input Specifications, MWE1W, for CE Approved & Export

SUPPLY REQUIRED	TOTAL KW LOAD			NOMINAL AMPS PER LINE									MENNEKES PLUG & RECEPTACLE MAY BE REQUIRED
				380V			400V			415V			
	380V	400V	415V	L1	L2	L3	L1	L2	L3	L1	L2	L3	
INPUT	10.6	10	10.6	16.1	16.1	16.5	15.3	15.3	15.3	14.8	14.8	15.1	748

The specifications on this sheet are for the exclusive use of licensees of the McDonald's Corporation.

Manufactured Exclusively for McDonald's by:
Garland Commercial Ranges Ltd
1177 Kamato Road, Mississauga ON L4W 1X4
Phone: (905) 624-0260 • Fax: (905) 624-1851 • Toll Free (800) 427-6668



Form# MWE1W (16 Jan 12)