



1-Platen Slim Electric Clamshell Grill w/Product Recognition

1-Platen Slim Electric Clamshell Grill w/Product Recognition

Model: MWE1S



Product Features:

- Product Recognition technology that automatically senses the food product placed on the grill yields faster, flexible operation and reduces waste.
- Proven one-platen design with auto-calibration of platen for gapping precision, consistent product quality and expanded self diagnostics.
- LonWorks® technology to network the grill into the “kitchen of the future,” reducing energy consumption and increasing operational efficiency.
- No access of upper platen required for adjustments and simple motorized movement of upper platen minimizes components.
- Two year parts and labor warranty.

The Garland Clamshell grill, manufactured exclusively for McDonald’s, provides a method for efficient two-sided cooking, while accommodating a variety of products. This grill meets all of McDonald’s standards for safety, efficiency, and cleanliness.



The specifications on this sheet are for the exclusive use of licensees of the McDonald’s Corporation.

Manufactured Exclusively for McDonald’s by:
Garland Commercial Ranges Ltd.
 1177 Kamato Road, Mississauga ON L4W 1X4
 Phone: (905) 624-0260 • Fax: (905) 624-1851 • Toll Free: (800) 427-6668





1-Platen Slim Electric Clamshell Grill w/Product Recognition

1-Platen Slim Electric Clamshell Grill w/Product Recognition

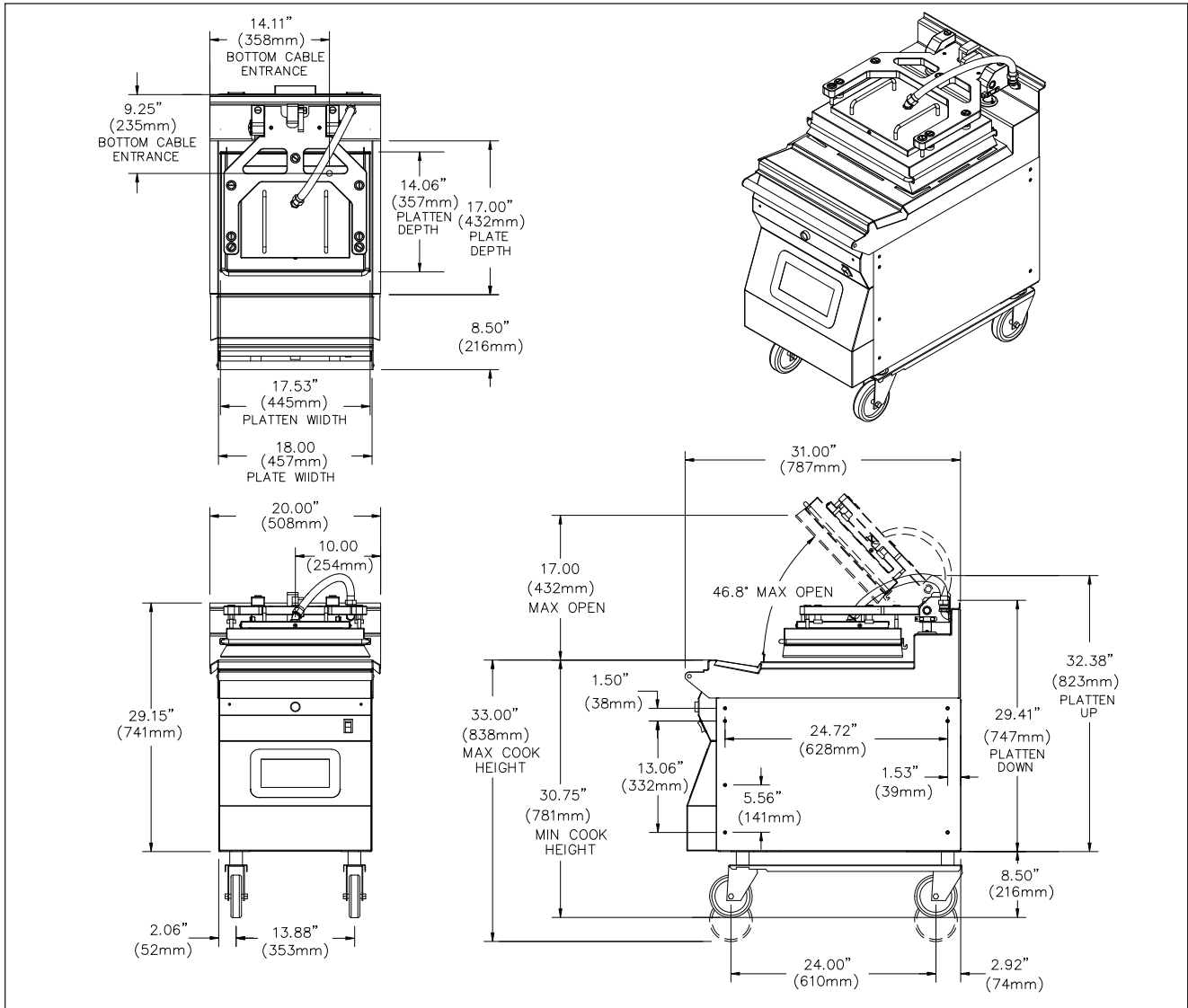

Input Specifications, MWE1S, for CE Approved & Export

SUPPLY REQUIRED	TOTAL KW LOAD	NOMINAL AMPS PER LINE									MENNEKES PLUG & RECEPTACLE MAY BE REQUIRED
		380V			400V			415V			
		L1	L2	L3	L1	L2	L3	L1	L2	L3	
INPUT	8.1	16.1	16.1	5.1	15.3	15.3	4.9	14.7	14.7	4.7	748

The specifications on this sheet are for the exclusive use of licensees of the McDonald's Corporation.

Manufactured Exclusively for McDonald's by:
Garland Commercial Ranges Ltd
1177 Kamato Road, Mississauga ON L4W 1X4
Phone: (905) 624-0260 • Fax: (905) 624-1851 • Toll Free (800) 427-6668



Form# MWE1S (18 Jan 12)