



2-Platen Electric Clamshell Grill w/Product Recognition



2-Platen Electric Clamshell Grill w/Product Recognition

Model: MWE2W, CE



Product Features:

- Product Recognition technology that automatically senses the food product placed on the grill yields faster, flexible operation and reduces waste.
- Proven two-platen design with auto-calibration of each platen for gapping precision, consistent product quality and expanded self diagnostics.
- LonWorks® technology to network the grill into the “kitchen of the future,” reducing energy consumption and increasing operational efficiency.
- No access of upper platen required for adjustments and simple motorized movement of upper platen minimizes components.
- Two year parts and labor warranty.

The Garland Clamshell grill, manufactured exclusively for McDonald’s, provides a method for efficient two-sided cooking, while accommodating a variety of products. This grill meets all of McDonald’s standards for safety, efficiency, and cleanliness.



The specifications on this sheet are for the exclusive use of licensees of the McDonald’s Corporation.

**Manufactured Exclusively for McDonald’s by:
Garland Commercial Ranges Ltd.**

1177 Kamato Road, Mississauga, ON. L4W 1X4

Phone: (905) 624-0260 • Fax: (905) 624-1851 • Toll Free: (800) 427-6668





2-Platen Electric Clamshell Grill w/Product Recognition

2-Platen Electric Clamshell Grill w/Product Recognition

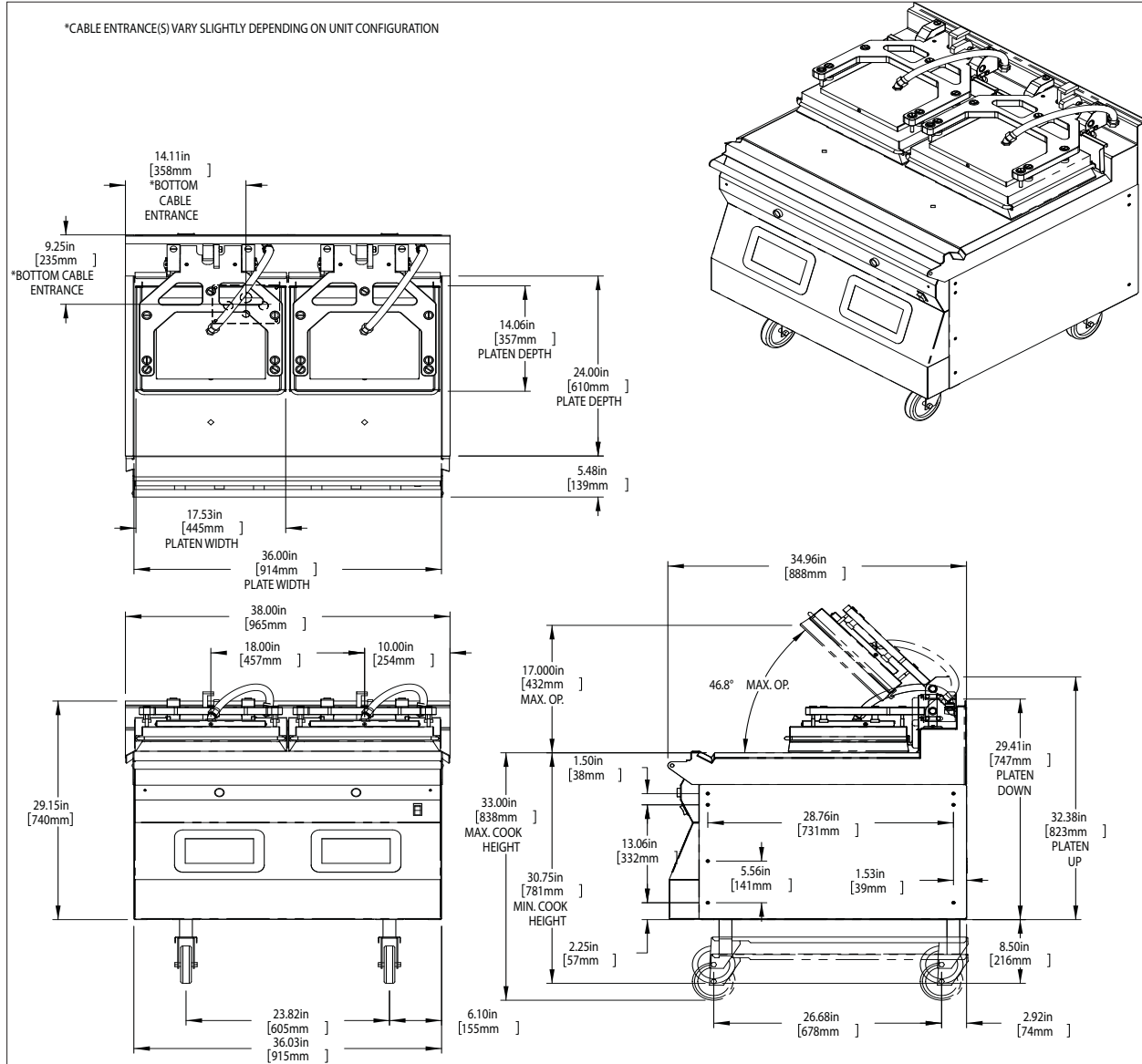

MWE2W,CE WYE CONFIG														
SUPPLY REQUIRED	TOTAL KW LOAD	NOMINAL AMPS PER LINE												MENNEKES PLUG & RECEPTACLE MAY BE REQUIRED
		380V (220V-N)				400V (230V-N)				415V (240V-N)				
		L1/N	L1	L2	L3	L1/N	L1	L2	L3	L1/N	L1	L2	L3	
INPUT	22.0	2.10	33.5	33.4	33.4	2.00	31.9	31.8	31.8	1.98	30.7	30.6	30.6	748

The specifications on this sheet are for the exclusive use of licensees of the McDonald's Corporation.

Manufactured Exclusively for McDonald's by:
Garland Commercial Ranges Ltd.
 1177 Kamato Road, Mississauga, ON. L4W 1X4
 Phone: (905) 624-0260 • Fax: (905) 624-1851 • Toll Free (800) 427-6668



Form# MWE2W,CE (8Jun11)