

ELECTRIC

MODEL NUMBERS

MWE-9501
MWE-9801
MWEH-9501
MWEH-9801
MWEF-9501
MWEL-9501
MWER-9501
MWEFH-9501



GARLAND

OPERATIONS MANUAL

CE APPROVED

MANUFACTURED EXCLUSIVELY FOR
McDonald's
BY

GARLAND COMMERCIAL INDUSTRIES, INC.

185 EAST SOUTH STREET

FREELAND, PENNSYLVANIA 18224

TOLL FREE: (800) 446-8367

PHONE: (570) 636-1000

FAX: (570) 636-9874

Come visit us on the web at

www.garland-group.com

E-mail: clamshell@garland-group.com



NOTE: This manual pertains to all grill models listed above. The reader/operator must interpret its contents to applicable needs. However, if there is any question of interpretation of any literature pertaining to Garland grills, please contact our Customer Service Department at one of the phone numbers listed above.

WARNING:

IMPROPER INSTALLATION, ADJUSTMENT, ALTERATION, SERVICE OR MAINTENANCE CAN CAUSE PROPERTY DAMAGE, INJURY OR DEATH. READ THE INSTALLATION, OPERATING AND MAINTENANCE INSTRUCTIONS THOROUGHLY BEFORE INSTALLING OR SERVICING THIS EQUIPMENT.

PLEASE READ ALL SECTIONS OF THIS MANUAL AND RETAIN FOR FUTURE REFERENCE.

CAUTION: THIS EQUIPMENT MUST ONLY BE OPERATED UNDER AN APPROVED HOOD SYSTEM

THIS EQUIPMENT "MUST" BE INSTALLED AND COMMISSIONED BY A PROFESSIONAL FACTORY TRAINED TECHNICIAN



Table of Contents

Table of Contents

| | |
|--|----|
| WARRANTY | 5 |
| INTRODUCTION | 5 |
| SAFETY | 5 |
| SHIPPING DAMAGE CLAIM PROCEDURE | 6 |
| CLEANING AND MAINTENANCE | 6 |
| FULL SIZE ELECTRIC GRILL MODEL MWE-9501..... | 8 |
| SPECIFICATIONS | 8 |
| HALF SIZE ELECTRIC GRILL MODEL MWEH-9501..... | 9 |
| 2/3 “SLIM GRILL” MODEL MWE-9801..... | 10 |
| 2/3 “SLIM GRILL” HALF SIZE MODEL MWEH-9801..... | 11 |
| FULL SIZE FLAT GRILL MODEL MWEF-9501..... | 12 |
| RELEASE MATERIAL INSTALLATION | 13 |
| RELEASE MATERIAL INSTALLATION (OPTIONAL) | 14 |
| UNIT INSTALLATION | 16 |
| 2-SPEED FAN INTERFACE INFORMATION (STANDARD AND WESTERN CANADA) | 16 |
| CLAMSHELL GRILL CONTROLS | 18 |
| DESCRIPTION OF GRILL CONTROLS | 19 |
| General Overview..... | 19 |
| The Master Power (Pushbutton (ON / OFF))..... | 19 |
| Indicator Lights..... | 19 |
| Up Arrow Button - Two Functions..... | 19 |
| Program Mode Button - Two Functions..... | 19 |
| Temperature / Function Button - Two Functions..... | 19 |
| Menu Button - Two Functions..... | 19 |
| Right Arrow Button - Two Functions..... | 19 |
| NORMAL OPERATING MODES | 20 |
| To Cook in Clam Grill Mode:..... | 20 |
| Standby Button - Black..... | 20 |
| Preheat Mode (Eprom 6.20 and higher)..... | 20 |
| Cancel / Raise Button - Green..... | 20 |
| To Cook in Flat Grill Mode:..... | 20 |
| Standby Mode:..... | 21 |
| EXIT the Standby Mode:..... | 21 |
| Standby Alarm (Version 6.20 and higher)..... | 21 |
| To Display the Current Temperature..... | 21 |
| To View Settings for a Menu Item:..... | 21 |
| To Reset Factory Defaults..... | 21 |
| To Clean the Grill:..... | 22 |
| Breakfast to Lunch Transition (Transition Cooking)..... | 22 |
| Multi-Stage Cooking..... | 22 |
| PROGRAM LOGIC CHART | 23 |
| To Display Temperatures in F or C..... | 24 |
| SYSTEM SETUP | 24 |
| To Change the Speaker Volume (High / Low)..... | 24 |
| To Change the Gap Calibration..... | 24 |
| To Enable / Disable Start Delay..... | 24 |
| To Change Start Delay Timer..... | 25 |
| To Change the Standby Alert Feature - EPROM Chip Ver. 6.20 and higher..... | 25 |
| To Enable / Disable Multi-Stage Cooking - EPROM Chip Ver. 7.XX and higher..... | 25 |
| MENU ITEMS | 26 |
| To Add or Delete a Menu Item..... | 26 |
| To Change the Remove Time..... | 26 |
| To Change the Remove Time Alarm (Auto/Manual)..... | 26 |
| To Change the Sear Time..... | 27 |
| To Change the Sear Time Alarm (Auto/Manual)..... | 27 |
| To Change the Toast Buns Time..... | 27 |
| To Change the Toast Buns Alarm (Auto/Manul)..... | 27 |
| To Change Turn Time..... | 28 |
| To Change Turn In Alarm (Auto / Manual)..... | 28 |
| To Change the grill surface set temperature..... | 28 |
| To Change the upper platen set temperature..... | 29 |
| To Enable High Limit Test - GRILL SURFACE (Chip V. 3.52 and 4.0* ONLY)..... | 29 |

TABLE OF CONTENTS

| | |
|--|----|
| <i>To Enable High Limit Test - PLATEN (Chip V. 3.52 and 4.0* ONLY)</i> | 29 |
| TO ADD / PROGRAM NEW MENU ITEMS | 30 |
| <i>To Add / Program an [Option Menu - CLAM]</i> | 30 |
| <i>To Add / Program an [OPTION MENU - FLAT]</i> | 31 |
| PROBE CALIBRATION | 32 |
| OPTIONAL ACCESSORIES | 34 |
| TROUBLESHOOTING | 35 |
| POSSIBLE ERROR MESSAGES | 35 |
| <i>"Eprom Corrupt"</i> | 35 |
| <i>"Probe Open"</i> | 35 |
| <i>"Clam did not go down"</i> | 35 |
| <i>"Upper Platen Stuck"</i> | 35 |
| <i>"High Limit"</i> | 35 |
| <i>"Motor Overcurrent"</i> | 35 |
| <i>"Faulty Element / Shorted Probe"</i> | 35 |
| IN STORE TROUBLESHOOTING GUIDE | 36 |
| CONTROLLER MENU ITEMS | 37 |
| CONTROLLER MENU ITEMS (EPROM CHIP VER. 7.XX) | 39 |
| TEMPERATURE CONVERSION (F / C) | 41 |
| MANUAL CORRECTIONS AND MODIFICATIONS | 43 |

WARRANTY

This warranty covers defects in material and workmanship under normal use providing that:

- a) the equipment has not been accidentally or intentionally damaged, altered or misused.
- b) the equipment is properly installed, adjusted, operated and maintained in accordance with national and local codes and in accordance with the installation instructions provided with this product.
- c) the warranty serial number affixed to the appliance by us has not been defaced, obliterated or removed.
- d) an acceptable report for any claim under this warranty is supplied to us.

The equipment warranty coverage remains in force for one (1) year (parts and labor) from the date the equipment is put into operation and two (2) years (parts only) for the microprocessor controller, motor speed controller and upper platen (aluminum casting and shroud).

The Garland Group agrees to repair or replace, at it's option, any part that proves to be defective in material or workmanship at no charge for the part or normal labor.

We assume no responsibility for installation, adjustments, diagnosis, or normal maintenance such as: lubrication of springs or valves. We exclude failures caused by erratic voltage or gas supplies. We assume no responsibility for travel costs beyond 100 miles round trip, travel other than overland, and overtime costs of repair. We exclude broken glass, paint and porcelain finish, surface rust, gasket material, ceramic material, light bulbs and fuses from normal coverage. We exclude damage or dysfunction caused by fire, flood, and like "Acts of God" that are beyond the control of The Garland Group.

The Garland Group's liability on a claim of warranty shall not exceed the price of the material and/or service, which caused the claim. This warranty is limited and is in lieu of all other warranties, expressed or implied. The Garland Group, our employees, or our agents shall not be held liable for any claims of personal injury or consequential damage or loss. This warranty gives you specific legal rights, and you may have other rights which vary from state to state.

INTRODUCTION

The Garland clamshell grill complies with the essential requirements of the Directives 89/109/EEC, 73/23/EEC, 89/336/EEC, and the standards, EN60335, IEC801.2, IEC801.3, IEC801.4, IEC801.5, IEC801.6, IEC801.11.

The Garland clamshell grill, manufactured exclusively for McDonald's, provides a method for efficient two-sided cooking, while accommodating a variety of products. The unit will also serve as a flat grill, and meets all of McDonald's standards for safety, efficiency, and cleanliness.

SAFETY

Always follow these safety precautions when operating the clamshell grill.

THIS GRILL MUST be operated by persons who have been given adequate training.

CAUTION: THIS EQUIPMENT MUST ONLY BE OPERATED UNDER AN APPROVED HOOD SYSTEM.

DO NOT OPERATE THE GRILL UNLESS IT HAS BEEN COMMISSIONED (START-UP) BY A FACTORY AUTHORIZED SERVICE CENTER.

DO NOT operate the grill without reading this operation manual.

DO NOT operate the clamshell grill unless it has been properly installed and grounded.

DO NOT operate the clamshell grill unless all service and access panels are in place and fastened properly.

The Garland clamshell grill is a semi-automatic cooking appliance. The upper platen is lowered automatically, following the manual; two-handed initiation of the cooking cycle, and the upper platen is raised automatically upon completion of the cooking cycle.

When two sided cooking, the area between the upper platen and the griddle plate should be regarded as a "danger zone". During two sided cooking the operator must not be within this danger zone. When used as a flat grill, then this area is no longer a danger zone, the platens do not move.

For whatever reason, be it cleaning, maintenance, normal operation, any exposed person must use extreme caution if within this danger zone.

In two side cooking the upper platen remains in the lowered position by nature of it's own weight. It is not locked down. It can be raised by lifting of the handle on the front of the platen, which pivots the platen about its rear mounting point.

The clamshell grill may during its operation emit airborne noise equivalent to a continuous A weighted sound pressure level of 73dB(A).

The clamshell grill must only be used for single and two sided cooking of foodstuffs in a McDonald's store and must not be used for any other purpose.

WARNING: To avoid serious personal injury:

DO NOT attempt to repair or replace any part of the clamshell grill unless all main power supplies to the grill have been disconnected.

USE EXTREME CAUTION in setting up, operating and cleaning the clamshell grill to avoid coming in contact with hot grill surfaces or hot grease. Suitable protective clothing should be worn to prevent the risk of burns.

WARNING: This appliance must not be cleaned with a water jet. **DO NOT** apply ice to a **HOT** grill surface.

NOTE: All warning labels and markings on the grill, which call attention to further dangers and necessary precautions.

HAZARD COMMUNICATION STANDARD, (HCS) - The procedures in this manual include the use of chemical products. These chemical products will be printed in bold face, followed by the abbreviation (HCS) in the text portion of the procedure. See the Hazard Communication Standard, (HCS) manual for the appropriate Material Safety Data Sheet(s), (MSDS).

WARNING: After turning the master power switch to the **START** position, the grill will go through an initialization process. If the upper platens are in the lowered position they will return to their raised upper position. This movement takes approximately 8 seconds.

MAINTENANCE - the platen support arms carriage block bearing bushes, the platen adjuster nuts, the platen support (shoulder) bolt and the cam follower should be checked annually for wear. Should there be any noticeable play in the bearing bushes and any visible wear on the platen adjuster nuts, platen support bolts or cam follower, then they must be replaced.

MAINTENANCE - the audible alarm that sounds on platen lowering, platen raising and 5 seconds before the completion of the cooking cycle is to advise the operator that the platen is about to move. The function of this device may be tested by pushing the left hand **CANCEL** button. If no sound is heard, ensure that the alarm volume is not set to low in **SYSTEM SETUP**. If there is still no sound then a service engineer should be called out to rectify the fault.

SERVICE AND CLEANING - The grill is secured in the grill bay by the installer using two anchors that lock onto the front casters. If the grill is to be moved out of the bay for cleaning or service, remove the anchor from each caster by turning the knob counterclockwise to loosen the retainer. When the retainer is free of the caster, lay the assembly aside

on the floor.

NOTE: The anchor assembly remains fastened to the back wall of the grill bay.

After service or cleaning is complete, return the grill to its position in the bay and reattach the anchors by placing the retainer on the caster post and turning the knob clockwise to tighten.

NOTE: For safety reasons, the grill must be secured in the grill bay in this manner before operation can resume.

SHIPPING DAMAGE CLAIM PROCEDURE

Please note that the Garland equipment was carefully inspected and packed by skilled personnel before leaving the factory. The transportation company assumes full responsibility for safe delivery upon acceptance of the equipment.

What to do if the equipment arrives damaged:

1. File a claim immediately regardless of the extent of damage.
2. Be sure to note, "visible loss or damage," on the freight bill or express receipt and have the person making the delivery sign it.
3. Concealed loss or damage: if damage is unnoticed until the equipment is unpacked, notify the freight company immediately, (within 15 days), and file a concealed damage claim.

CLEANING AND MAINTENANCE

Tools: McD Hi-Temp Grill Cleaner (HCS), McD All Purpose Super Concentrate (HCS), McD's **NO-SCRATCH**(Pad and Pad Holder, a suitable container, High-Temperature Pot Brush and Grill Cloth, Stainless Steel Pan Filled With Lukewarm Water, Protective Gloves, (to protect hands from heat), Grill Squeegee and Grill Scraper.

Warning: The upper platen surface and edges are very hot! To prevent burn injuries, use extreme caution when wiping down release sheets and platen edges.

Important: Frequently throughout the day, (at least 4 times per hour), thoroughly wipe down the release sheets and platen edges with a damp grill cloth.

1. **PRESS** the "MENU" button until "CLEAN MODE" is displayed, (the control will maintain the proper cleaning temperature). Repeat with the other control. "READY TO CLEAN" will be displayed and an audible alarm will sound when the grill is at the proper cleaning temperature. **PRESS** the "MENU" button to display "OFF." The "OFF" position on the controllers allows the operator to

raise and lower the upper platens, (for clamshell grills), to alternate positions for proper cleaning of the platen edges.

2. Empty and replace the grease troughs. Grease troughs should be emptied and replaced consistent with store security policy.
3. Put on the protective gloves and wipe down the exposed surface of the release sheet with a damp grill cloth.
4. Remove the release sheet locking clips and bars. Clean the release sheets following the instructions provided by your local cleaning chemical supplier.
5. Scrape only the lower grill surface with the grill scraper, and squeegee any residue into the grease troughs with the grill squeegee.

Caution: Do not scrape or otherwise scratch the upper platens. The use of metal scrapers, abrasive pads, or wire brushes will permanently damage the surface of the upper platens.

6. Open one packet of McD Hi-Temp Grill Cleaner, (HCS), and empty the contents into a suitable container. (One packet cleans a 3ft. grill).
7. Firmly attach the McD NO-SCRATCH(Pad to the pad holder.
8. Dip the NO-SCRATCH(Pad into the grill cleaner.
9. Spread a light coating of grill cleaner over the entire platen surface, BACK, FRONT AND SIDE EDGES of both upper platens. DO NOT SCRUB WHILE APPLYING THE PRODUCT.
10. After applying the grill cleaner, lightly scrub the platen surfaces, BACK, FRONT AND SIDE EDGES with the NO-SCRATCH(Pad until all the soil has been liquefied by the grill cleaner. For stubborn soils, apply additional grill cleaner and lightly scrub. DO NOT RINSE THE PLATENS AT THIS TIME.
11. Starting at the back of the lower grill, spread a light coating of grill cleaner over the entire surface. DO NOT SCRUB WHILE APPLYING THE PRODUCT.
12. After applying the grill cleaner, lightly scrub the grill surface with the NO-SCRATCH(Pad until all the soil has been liquefied
13. For Clamshell Grills, rinse the upper platens with a dripping wet grill cloth. RINSE PLATEN EDGE THOROUGHLY, THEN WIPE DOWN BACK EDGE OF PLATEN.
14. Carefully pour small quantities of lukewarm water onto the grill while brushing the surface, backsplash, and

bullnose with a LONGLIFE(pot brush or equivalent high-temperature brush. Continue until the water no longer boils away and the grill remains wet. Squeegee dry.

Caution: Ice, cold water, or large quantities of water must never be applied to the grill plate or upper platen. Severe damage to the grill will occur!

15. Clean the release sheets as follows:

16. Place the sheets on the lower grill. Scrub both sides of the sheets with the same McD NO-SCRATCH(Pad used on the grill.

Note: It is generally not necessary to apply additional product to the NO-SCRATCH(Pad. If the pad is not wet enough, rewet with a small amount of water, if no cleaner is left.

- a. Rinse both sides of the sheets with a wet grill cloth.
- b. Rinse the lower grill by flooding the surface twice with lukewarm water. Squeegee after each rinse.

17. Wipe the lower grill surface, backsplash, bullnose, and hood with a clean, damp grill cloth.

AFTER CLEANING - Apply a thin coat of fresh shortening to the lower grill surface only. Wipe down the surrounding areas. Empty, wash, rinse, and replace the grease troughs.

Note: Repeat this procedure to clean additional grills. Reverse NO-SCRATCH(Pad, and use clean side.

CLEANING AFTER EACH RUN OF PRODUCT:

Using grill scraper, scrape grease on lower grill plate from front to back only. Do not scrape across the rear of the lower grill plate with grill scraper. Use wiper squeegee to clean release material sheet on upper platen in a downward motion. Hold handle at a slight upward angle with wiper end facing downward. Do not press hard against the release material sheet to prevent scratching or tearing.

Push the grease at the rear of the lower grill plate into the grease cans using the wiper squeegee only. Do not use the grill scraper for this step.

Warning: Grill Temperatures will cause severe skin burns.

Use the grill cloth to clean back splash and bullnose areas as needed during operation.

Note: To increase life of release material sheet, wipe down with folded grill cloth four (4) times every hour.

SPECIFICATIONS

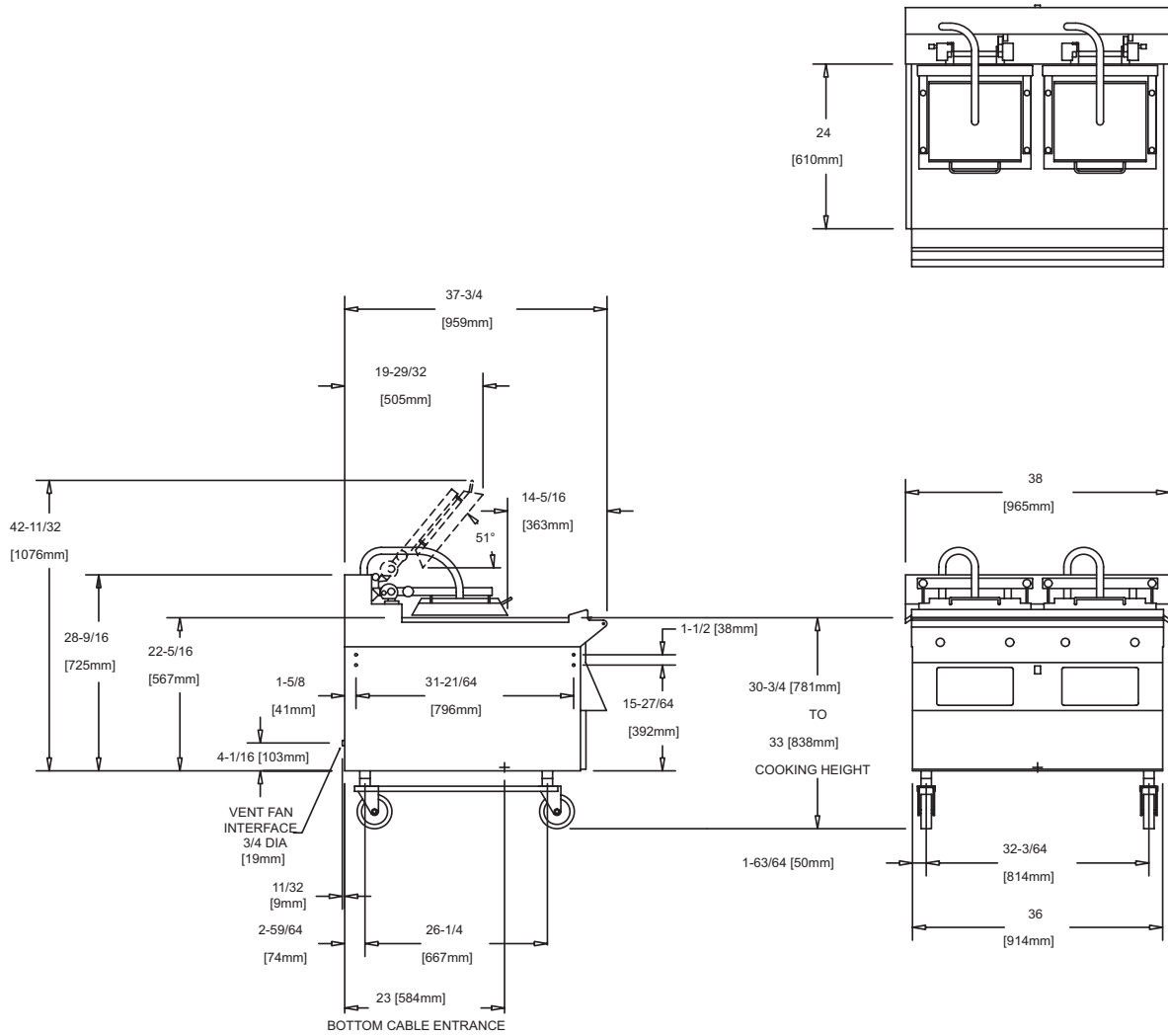

FULL SIZE ELECTRIC GRILL MODEL MWE-9501

| ELECTRICAL REQUIREMENTS 3N~400V 50HZ ONE 7 WAY SUPPLY CORD | KW LOAD AT 400 VOLTS | NOMINAL AMPERES PER LINE 400V | | | MENNEKES PLUG REQUIRED |
|--|----------------------|-------------------------------|------|------|------------------------|
| | | L1 | L2 | L3 | |
| ONE SEVEN WAY SUPPLY CORD | 20 | 28.9 | 31.1 | 28.9 | TYPE 748 |

SPECIFICATIONS

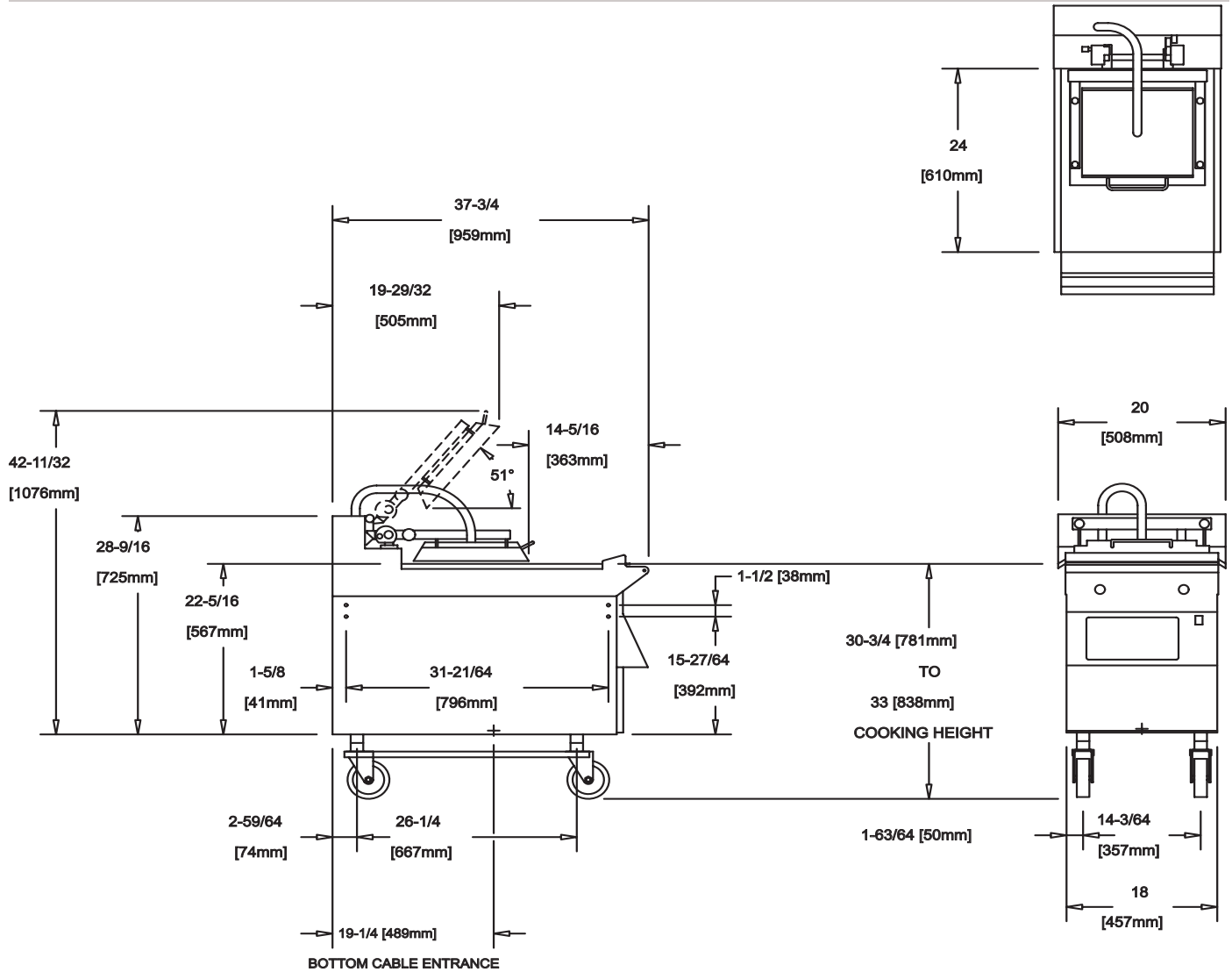

HALF SIZE ELECTRIC GRILL MODEL MWEH-9501

| ELECTRICAL REQUIREMENTS 3N-400V 50HZ ONE 7 WAY SUPPLY CORD | KW LOAD AT 400 VOLTS | NOMINAL AMPERES PER LINE 400V | | | MENNEKES PLUG REQUIRED |
|--|----------------------|-------------------------------|------|------|------------------------|
| | | L1 | L2 | L3 | |
| ONE SEVEN WAY SUPPLY CORD | 10 | 14.5 | 14.5 | 14.5 | TYPE 748 |

SPECIFICATIONS

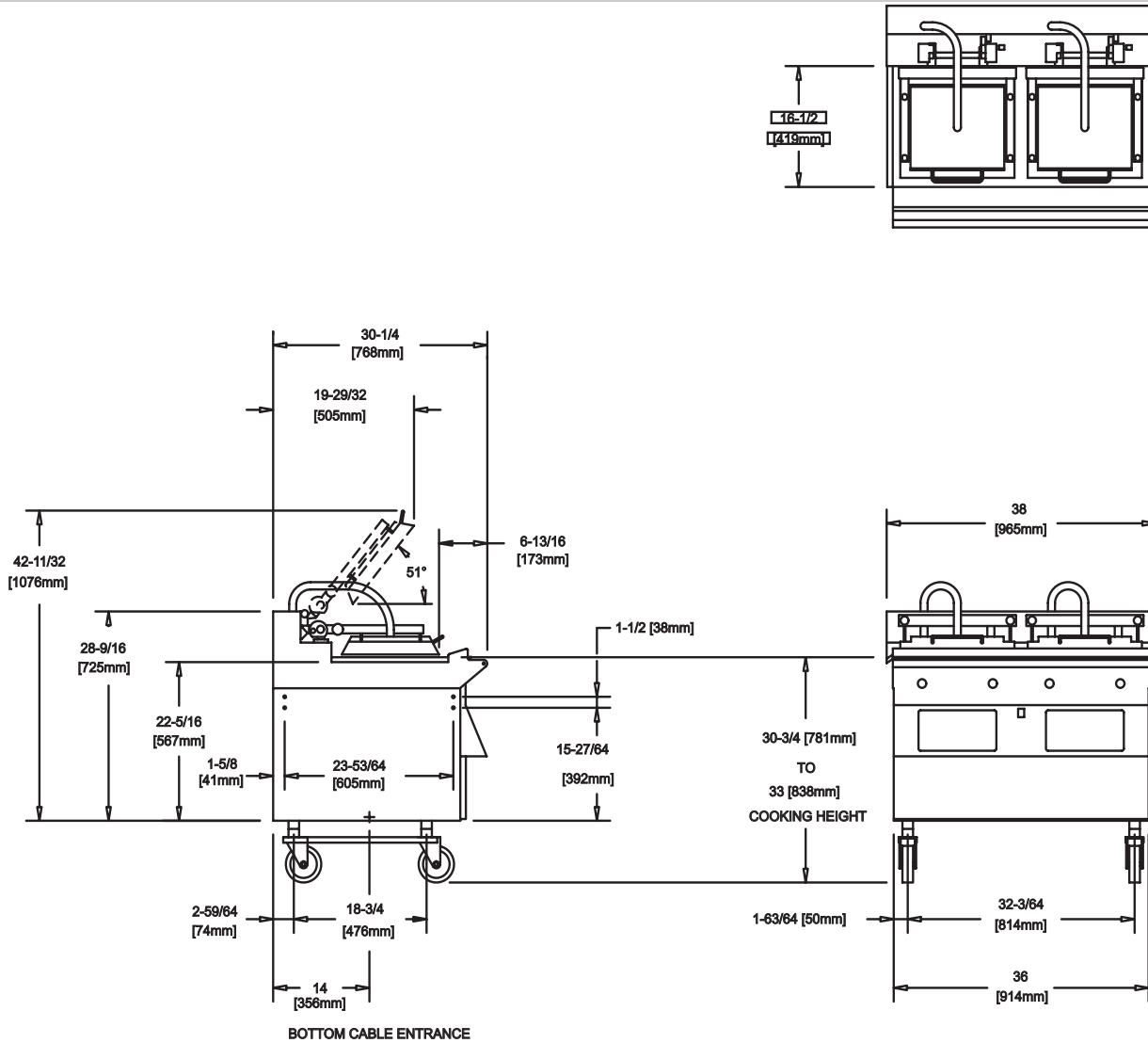

2/3 "SLIM GRILL" MODEL MWE-9801

| ELECTRICAL REQUIREMENTS 3N~400V 50HZ ONE 7 WAY SUPPLY CORD | KW LOAD AT 400 VOLTS | NOMINAL AMPERES PER LINE 400V | | | MENNEKES PLUG REQUIRED |
|--|----------------------|-------------------------------|----|------|------------------------|
| | | L1 | L2 | L3 | |
| ONE SEVEN WAY SUPPLY CORD | 16.7 | 24.3 | 22 | 26.2 | TYPE 748 |

SPECIFICATIONS

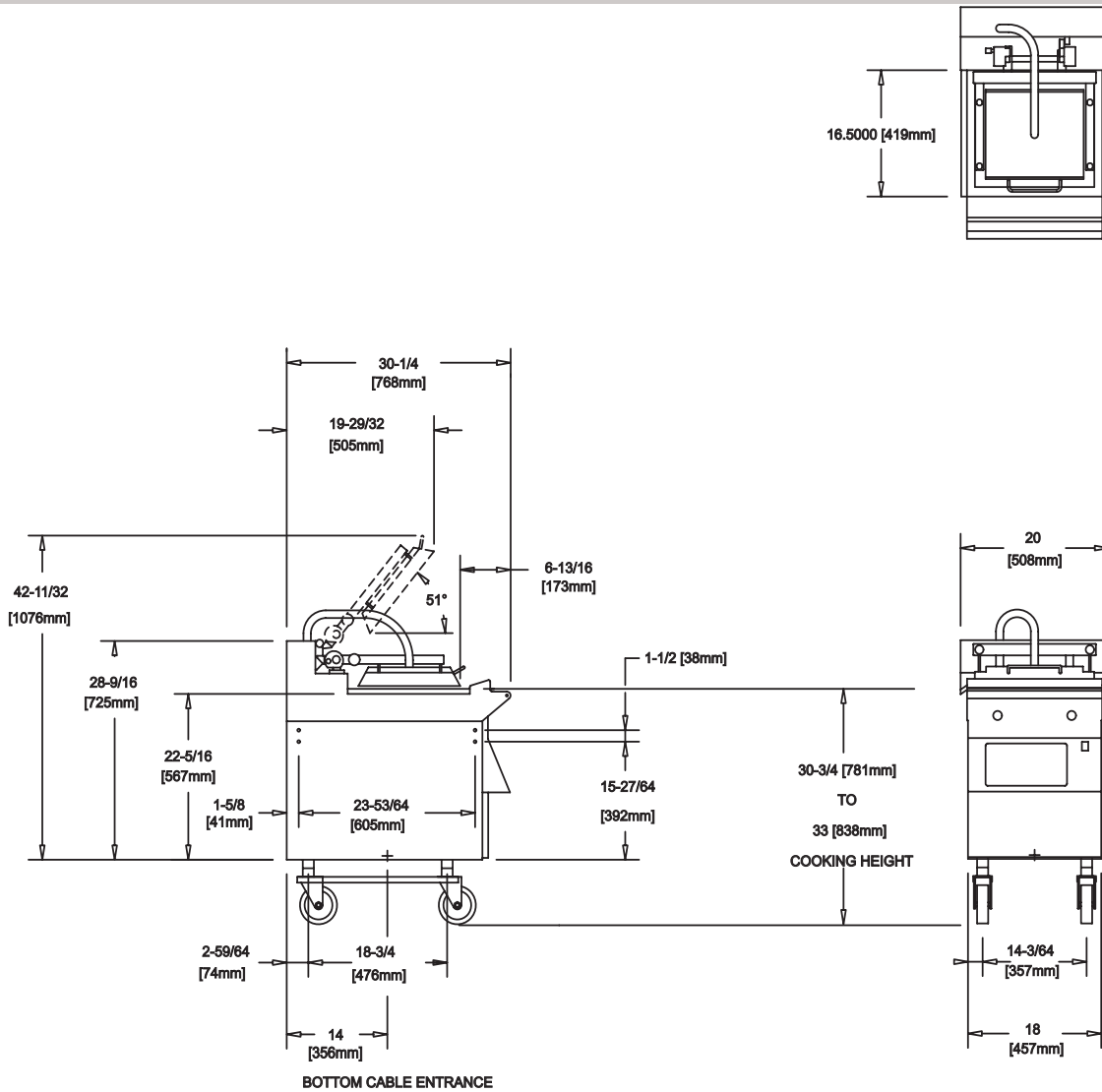

2/3 "SLIM GRILL" HALF SIZE MODEL MWEH-9801

| ELECTRICAL REQUIREMENTS 3N-400V 50HZ ONE 7 WAY SUPPLY CORD | KW LOAD AT 400 VOLTS | NOMINAL AMPERES PER LINE 400V | | | MENNEKES PLUG REQUIRED |
|--|----------------------|-------------------------------|------|------|------------------------|
| | | L1 | L2 | L3 | |
| ONE SEVEN WAY SUPPLY CORD | 8.6 | 10.9 | 15.4 | 11.2 | TYPE 748 |

SPECIFICATIONS

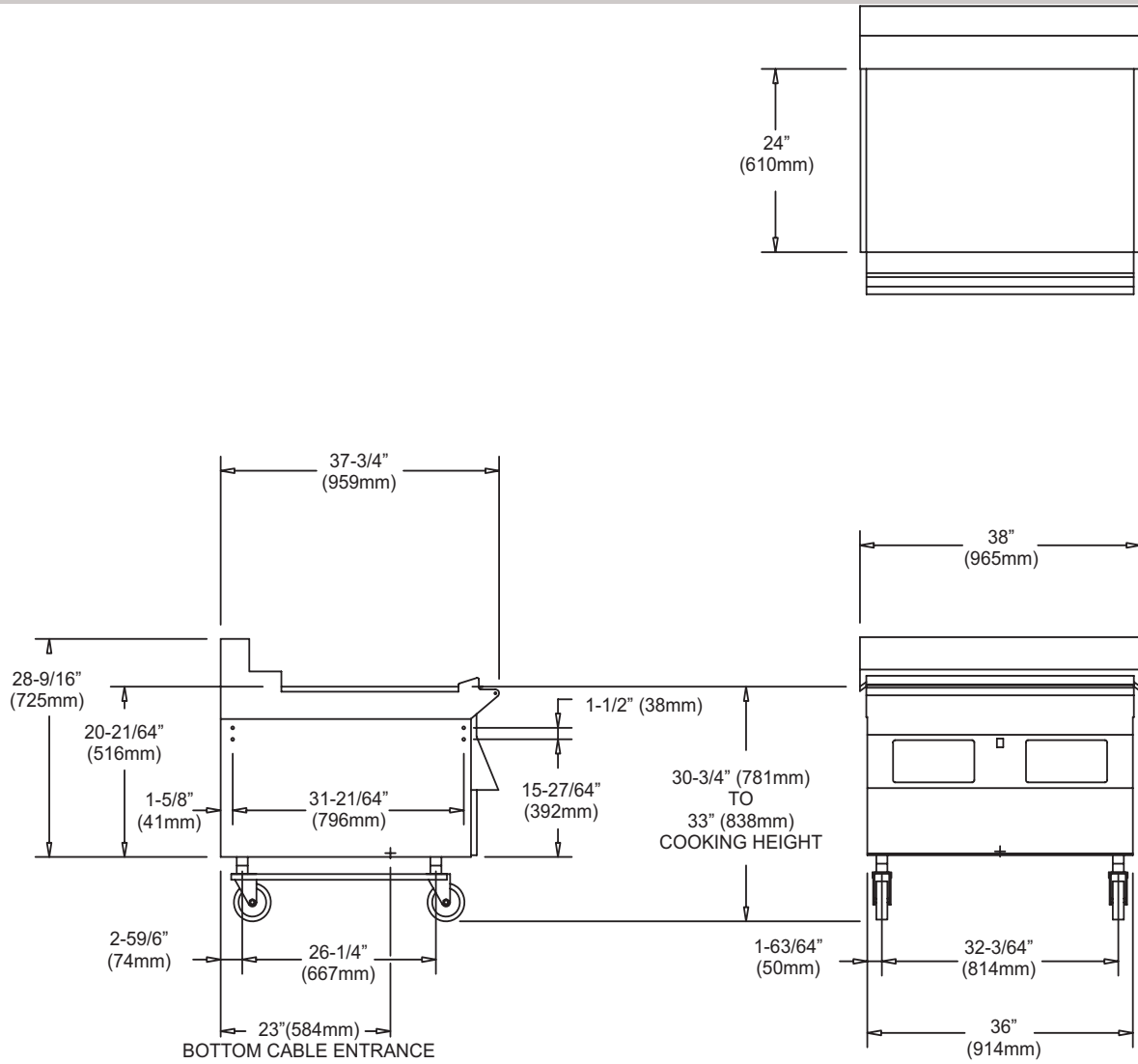

FULL SIZE FLAT GRILL MODEL MWEF-9501

| ELECTRICAL REQUIREMENTS 3N~400V 50HZ ONE 7 WAY SUPPLY CORD | KW LOAD AT 400 VOLTS | NOMINAL AMPERES PER LINE 400V | | | MENNEKES PLUG REQUIRED |
|--|----------------------|-------------------------------|----|----|------------------------|
| | | L1 | L2 | L3 | |
| ONE SEVEN WAY SUPPLY CORD | 13.8 | 20 | 20 | 20 | TYPE 748 |

RELEASE MATERIAL INSTALLATION

The following procedures are the procedures for installing the teflon sheets on to the upper platen on the Garland Clamshell grill. The components shown below are included with your grill when purchased.

1. Slide release material rod through hemmed end of the release material sheet.

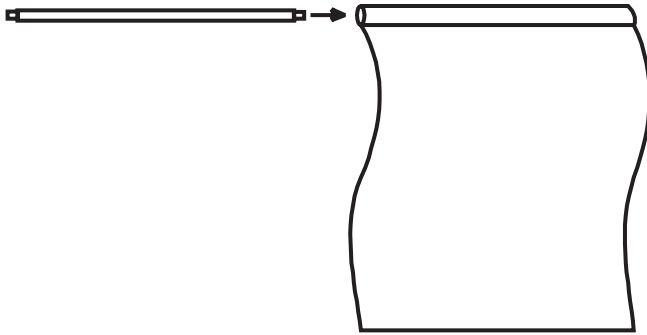

2. Hook release material rod on brackets located at the rear of the upper platen

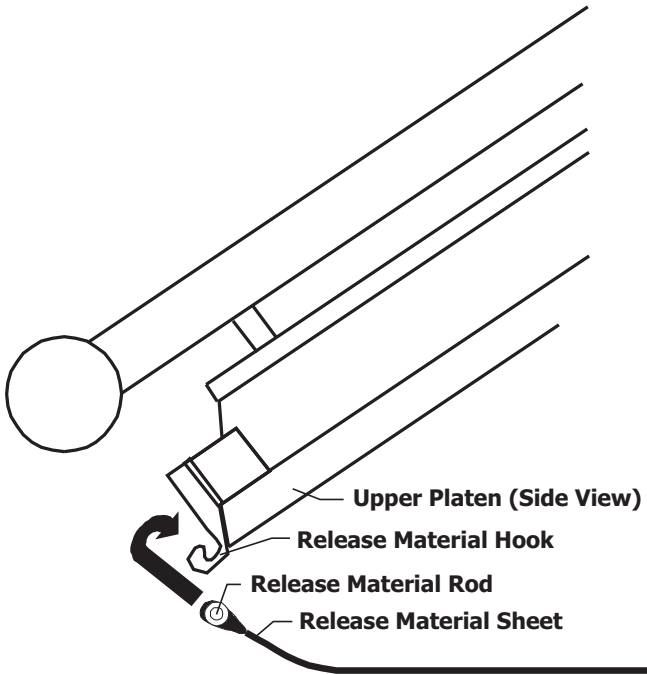

3. Holding the bottom of the release material sheet in place, gently pull the sheet toward the front of the platen.

NOTE: Make sure release material fits smoothly over upper platen.

4. Place locking clips over release material sheet and press into place over release material bar

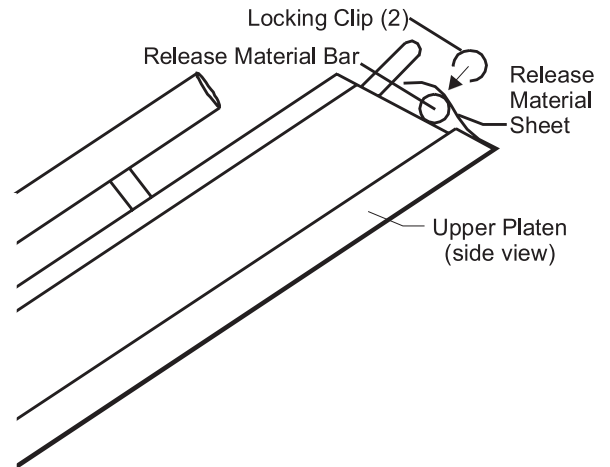

5. Check alignment and tightness of release material against upper platen.

NOTE: Installing release material sheets too tight may cause premature failure of the sheet.

Installing only 1 clip on over the release material bar may cause the release material sheet to be too loose. Ensure that 2 clips are installed on the teflon bar at all times.

Release material sheets should be replaced when:

- Product sticks to release material
- Carbon build-up causes problems in taste or appearance.
- A tear in the release material sheet's cooking area.
- Release material coating is worn off sheet.

NOTE: Rotate the release sheets on daily basis

RELEASE MATERIAL INSTALLATION (OPTIONAL)

NOTE: TEFLON ROLLUP BAR ASSEMBLY'S ARE SEPARATE FOR LEFT AND FOR RIGHT. NOTE THE "L" OR "R" STAMPED ON THE BRACKET ASSEMBLY FOR CORRECT POSITIONING.

WARNING: UPPER PLATEN TEMPERATURES ARE VERY HOT. PLATEN SHOULD BE COOL WHILE INSTALLING

1. If attached, remove Teflon sheet clips located on the front of the platen.
2. Insure Teflon bar that is bolted to the upper platen is free and clear of carbon buildup, and clean as necessary.
3. Install Teflon rollup bar bracket by placing new rollup over existing Teflon bar, with the set screws facing DOWN (See Figure 1).
4. Tighten set screws using 1/8" allen wrench.

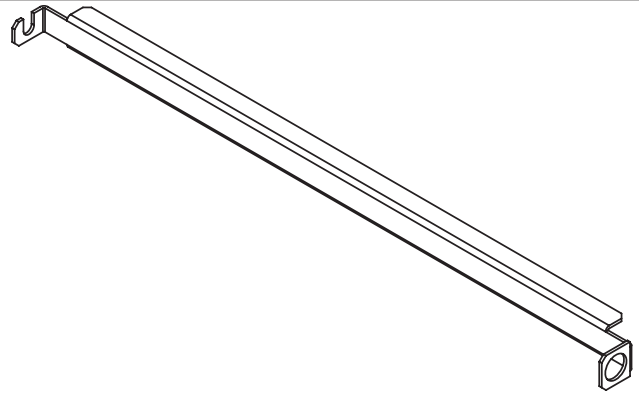

Figure 1 - Teflon Rollup bar bracket

5. Install teflon roller bar in rollup bracket. (See Figure 2)

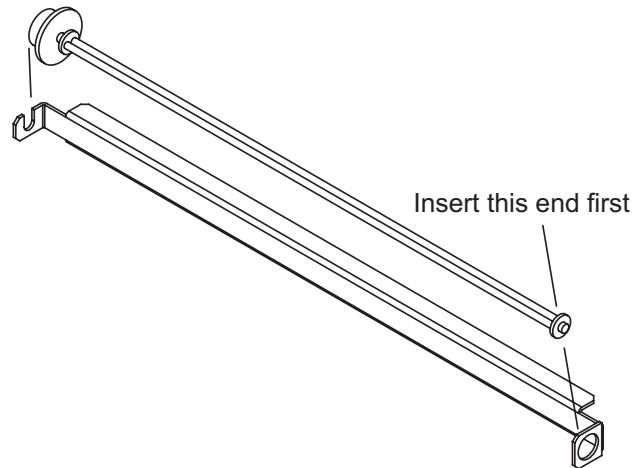
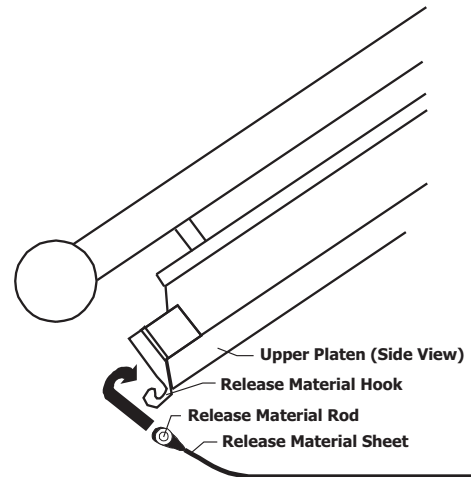
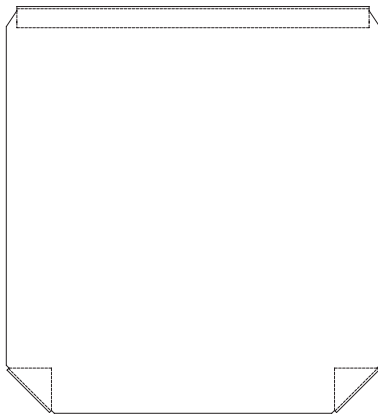
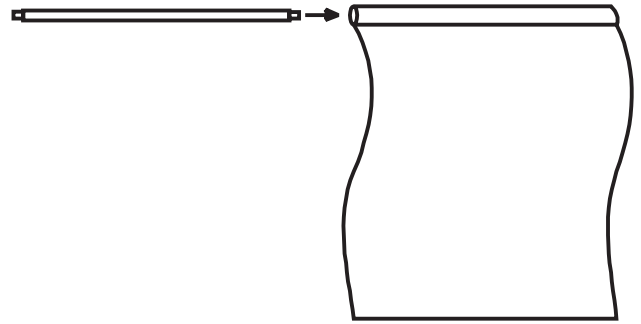

Figure 2 - Inserting teflon roller bar into bracket

RELEASE MATERIAL INSTALLATION (OPTIONAL)

6. Install existing rod through opening on teflon sheet as previously done with existing rod and sheet.
7. Clip existing teflon bar in rear of platen as previously done with existing rod and sheet.
8. Fold corner edges of front of teflon sheet approximately 1 inch on top and side, and insert folded sheet through opening in Teflon rollup.



9. Once inserted, pull through and hold Teflon sheet in center, and turn the tightening knob clockwise (for right platen) and counter-clockwise (for left platen).
10. Once tight, turn locking knob in opposite direction of tightening knob.

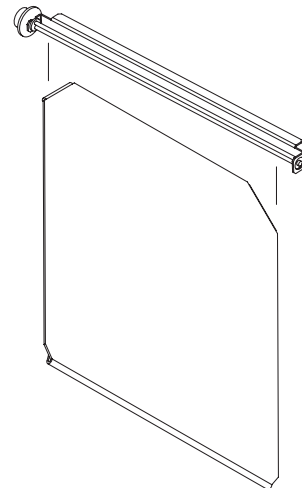

2-SPEED FAN INTERFACE INFORMATION (STANDARD AND WESTERN CANADA)

This unit is equipped with a 2-speed fan interface (Grills manufactured post grill serial number 0010CL0036). McDonalds stores built post May 2000 are equipped with the capability of a 2-speed interface. In the event that a store is a capable 2-speed fan store, and the grill is not a 2-speed fan unit, a separate 2-speed installation kit is available upon request at a set billable price to the store.

Units equipped with a 2-speed fan interface still require the 5-wire interlock cord, in addition to a separate 3-wire extension cord supplied from the hood exhaust system. 2-speed installation instructions are available upon request.

2-speed activation will occur at the following times:

LOW SPEED (all active AFTER (1) ONE MINUTE)

1. All platens (equipped and are active 2-speed fan grills) go into the standby mode. (For standby mode see page 23).
2. All platens (equipped and are active 2-speed fan grills) are in the OFF mode.
3. All platens (equipped and are active 2-speed fan grills) are idle (in the up position).
4. When grill is initially turned on for initial heat up in the morning.

HIGH SPEED (Active immediately)

1. A cook cycle on at least 1 platen (equipped and are active 2-speed fan grills) is initiated.
2. When grill is initialized using the main ON/OFF Master Power switch for 1 minute.
3. CLEAN MODE.

UNIT INSTALLATION

IMPORTANT: RATING PLATE FOR THIS EQUIPMENT IS LOCATED IN TWO PLACES. ONE IS LOCATED INSIDE BACK PANEL ON LEFT SIDE, SECOND RATING PLATE LOCATED UNDER FRONT CONTROL PANEL ON CENTER.

A competent person must install this appliance

This appliance should be connected to a potential equalization system. To facilitate this, a labeled equipment potential bonding point is fitted to the rear of the grill.

It is recommended that this grill is connected to a residual current (earth leakage) device with a tripping current not exceeding 30mA. The leakage current of this grill will not exceed 5mA.

This grill may be supplied with a seven-pin socket, as specified by McDonald's Corporation, for installation in new grill stations. This socket is supplied loose with the grill, complete with its wiring harness. This socket **MUST** be located on the underside of the grill, using the mounting holes provided and wired to the internal terminal block according to the wiring diagram provided on the rear of the appliance and in this manual. This socket allows for disconnection from the supply with all pole separation of at least 3mm.

For connection to existing older grill stations, please refer

to your Kitchen Equipment Supplier for a conversion kit that allows connection to two power supply cords and one interlock cord. This kit must be connected according to the instructions and wiring diagram supplied with it and the warning labels supplied with the kit must be applied to the grill.

CAUTION: Prior to installation, check the electrical supply to ensure input voltage and phase match the equipment voltage rating and phase. See data plate located rear left side of grill. Back panel removal is required.

Grill is to be located directly under ventilation system and fit securely with grill locks attached.

Grill must be level front to back, side to side and diagonally.

WARNING: Electrical appliances must be electrically grounded in accordance with local codes or in the absence of local codes, with national electric code ANSUI/NFPA - latest version.

WARNING: Installer Note - This grill is designed for connection to a special interlock system. Check receptacle-wiring diagram before connecting.

Configuration may vary by area or country. Verify with the local regional operations department.

UNIT INSTALLATION

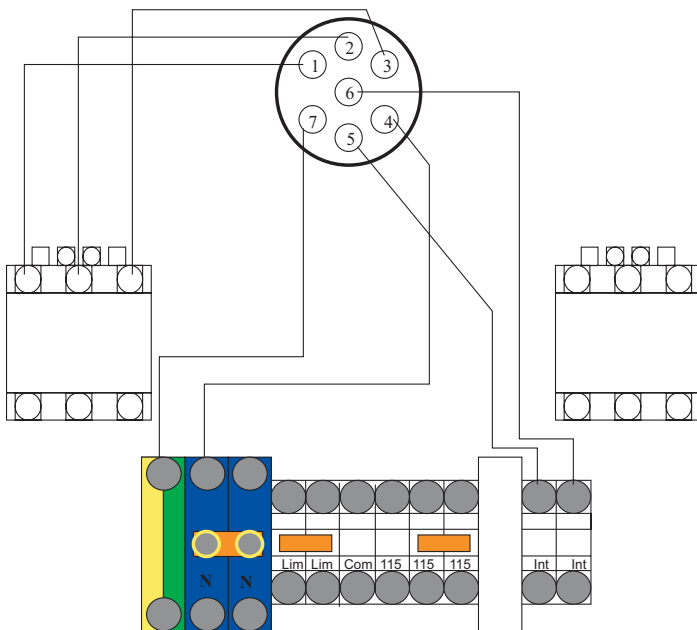
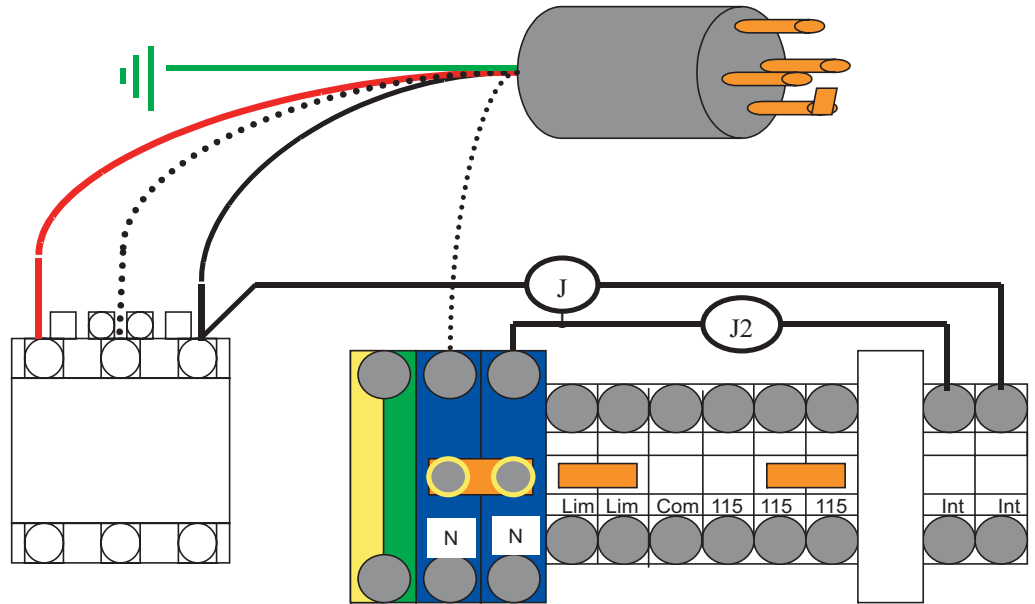

Mennekes 7 pin Socket / Plug

The Mennekes 7-pin Socket is used in International Units -CE, -H, -ME, -FR, and -K.

As shown in the diagram to the left, the Mennekes socket/plug is used to bring both single, and three phase voltage to the unit.

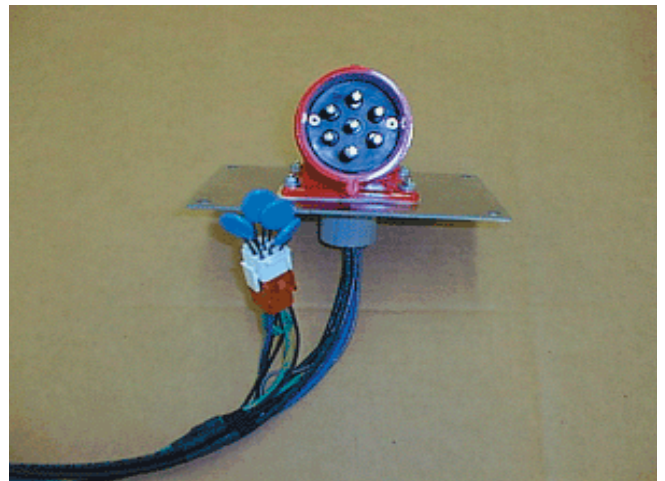

CLAMSHELL GRILL CONTROLS

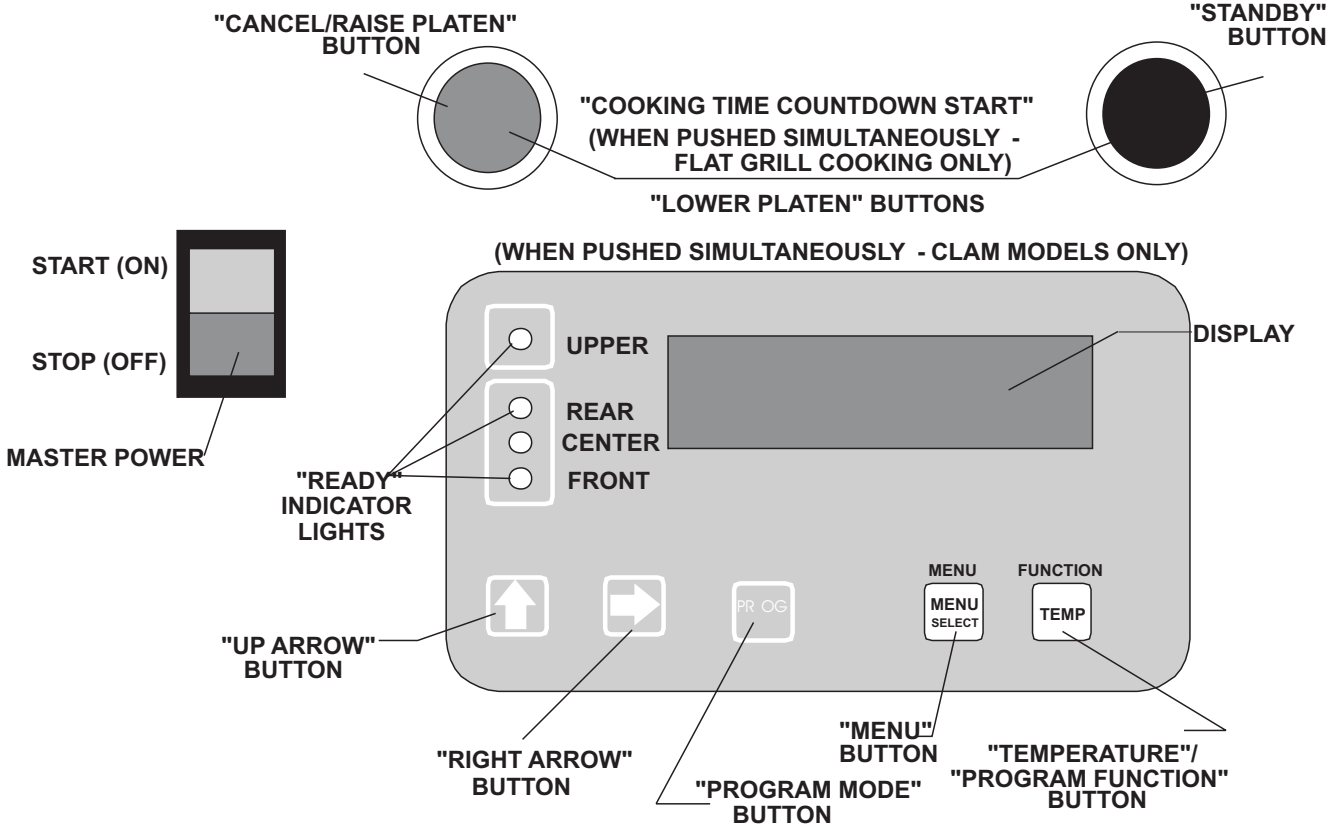

DESCRIPTION OF GRILL CONTROLS

General Overview

The grill control will allow for 2 functions, both described in the following sections.

The “**Normal Operating Mode**”, also known as the Cook Mode is the mode in which is used during normal cooking. In the normal operating mode, the operator can start a cook cycle, cancel a cook cycle, view actual temperatures, view settings for the currently selected menu item, scroll to another menu item (Both forward and backward), and enter the “**Programming Mode**”.

The “**Programming Mode**” is the mode in which the grill operator, manager, or service technician can change various programmed features to specific menu items, or change features that would apply to the entire grill.

The Master Power (Pushbutton (ON / OFF))

Controls power to the grill and must be turned "ON" to start the operation. The controller displays will be active when the switch is "ON".

Indicator Lights

There are four, (4), indicator lights, indicating the temperature status of each zone on the grill, one, (1), on the upper platen, (top light), and three, (3), on the lower, (lower section of lights, top to bottom; rear, center, front, respectively - see diagram on previous page). Each light can display three, (3), different colors, indicating temperature status for the corresponding zone.

Red: The zone(s) is too hot (more than 79°F/43°C over the set temperature) or heat zone(s) failure.

Amber: The zone(s) is calling for heat.

Green: The zone(s) is at or above the set temperature (maximum of 79°F/43°C).

Display:

The controller display will contain information relevant to each operation in both cook and program modes.

NOTE: ** Version 7.3X EPROM Chip ** - At the end of the pre-programmed menu item Round Eggs cook cycle, the rear LED (Gas Zone) will turn off for a period of 60 seconds. The LED (or heat) will remain off for the period of 60 seconds unless another cook cycle is initiated.

Up Arrow Button - Two Functions

1) In the cook mode, when depressed, it will display the Remove time, Top Temperature, Bottom temperature and Gap setting for the menu item displayed. Each item will be displayed in the order as stated above. After 5 seconds the display will return to the product menu item.

2) In the program mode, it will change the value of the current cursor digit, (see "RIGHT ARROW" button).

Right Arrow Button - Two Functions

1) In the program mode various displayed parameters will be shown in numerical values. Each number, when displayed, will have a flashing digit...the cursor digit. The "RIGHT ARROW" button will move the cursor to the next digit. Using the "RIGHT ARROW" button in conjunction with the "UP ARROW" button described above, any parameter value displayed in the program mode may be altered.

2) In the cook mode it will scroll backward through the menu items.

Program Mode Button - Two Functions

1) The primary function is to access Programming and Calibration of the grill. Push and hold for five (5) seconds. Display will show type and version number. There are two programming features,

"MENU ITEMS" and "SYSTEM SETUP".

2) The second function is when used with "TEMP" button. To display all temperature zones at the same time, press the "TEMP" button one time and the "PROG" button five (5) times. This will display all four (4) temperature zones.

Menu Button - Two Functions

1) In the cook mode this button will allow you to change menu items.

2) In the programming mode, the button is used to advance to the next program item.

Temperature / Function Button - Two Functions

1) In the Cook mode, each time the button is pressed the current temperature for one zone will be displayed. The displayed temperature begins at the upper platen and works sequentially to the front each time you press the button. After five (5) seconds the display will return to the menu item selected.

2) In the Program mode, this button becomes the Function button allowing you to scroll through the functions in the "MENU ITEMS" section of programming.

DESCRIPTION OF GRILL CONTROLS

Standby Button - Black

When both "STANDBY" and "CANCEL/RAISE" buttons are pressed simultaneously, the upper platen will lower to the griddle surface. Press the "STANDBY" button again within five (5) seconds from the start of the cook cycle, to place the controller in its "standby" state. The display will flash "STANDBY" along with the menu item currently selected. For energy conservation and periods of non-use this will maintain grill temperatures.

Cancel / Raise Button - Green

From the "STANDBY" mode, pushing this button will cancel "Standby" and raise platen. During the cooking cycle, pressing this button will cancel the cooking timer and return the grill to the "IDLE" mode.

NOTE: If the platen is in motion, pressing the "CANCEL/RAISE" button will stop the platen in motion and return the platen to the "IDLE" mode (Eprom version 3.52 and greater).

NORMAL OPERATING MODES

NOTE - TO STOP THE GRILL AT ANY TIME, TURN THE MASTER POWER SWITCH OFF

Preheat Mode (Eprom 6.20 and higher)

The first menu item selected after pressing the "MENU SELECT" button is "PREHEAT". Preheat mode is not actually a menu item, as it does not have a remove time.

Preheat mode has been designed to alarm the operator when the grill is "READY TO COOK".

The upper platen set temperature is 425° F (218°C) and a lower grill surface set temperature of 350°F (177°C). When the grill reaches these set temperatures, the operator can then select a menu item with equal set temperatures, and the grill will be ready to cook.

platen will raise and the display will flash "REMOVE" with an audible alert, then remove product per the prescribed method.

5. To cancel a cooking cycle, press the GREEN ("CANCEL/RAISE") button. The upper platen will rise. The display will flash "CANCEL" with an audible alert.

NOTE: If the alarm cancel is set to AUTO, the audible alert will sound five (5) seconds before timing is finished.

-OR-

If the alarm cancel is set to MANUAL, the audible alert will sound as the timing is finished.

To Cook in Clam Grill Mode:

1. SELECT a clam grill menu by pressing the "MENU SELECT" button, until you attain the required Clam menu item. The display may read either "TOO COOL" or "TOO HOT," (alternating with the "MENU ITEM"), until the grill attains the set temperature range for that menu, then the "MENU ITEM," (only), will be displayed.

NOTE: If the display reads either "TOO COOL" or "TOO HOT" the upper platen will not lower and initiate a cooking sequence.

2. After laying product in the prescribed method, press the GREEN ("CANCEL/RAISE") and the BLACK ("STANDBY") buttons at the same time. An audible alert will sound and the platen will lower to the preset gap and the timing will automatically start.
3. When the cook cycle times down to five, (5), seconds remaining, a pre-time-out alarm will sound to alert the grill operator.
4. When the cooking time has been completed, the upper

To Cook in Flat Grill Mode:

1. SELECT a flat menu by pressing the "MENU SELECT" button, until you attain the required menu item. The display may read either "TOO COOL" or "TOO HOT" (alternating with the "MENU ITEM") until the grill attains the set temperature for that menu.
2. After laying product in the prescribed method, press the GREEN, ("CANCEL/RAISE"), and the BLACK, ("STANDBY"), buttons at the same time, starting the cooking time countdown.

NOTE: If the display reads either "TOO COOL" or "TOO HOT" the controller will not initiate a cooking sequence.

3. PERFORM the required functions displayed, i.e.; sear, turn, to cancel the audible alerts, press the BLACK ("STANDBY") button.

CAUTION: Pressing the GREEN ("CANCEL/RAISE") button will cancel the cooking cycle, and pressing any other button on the controller will cancel the alarm.

NORMAL OPERATING MODES

4. When the cooking time has been completed, the display will flash "REMOVE" with an audible alert. Remove product per the prescribed method.

NOTE: If a required flat grill menu cannot be found, go to the programming mode (see programming, "MENU ITEMS").

Standby Mode:

1. SELECT a clam grill menu by pressing the "MENU SELECT" button, until you attain the required menu item.

NOTE: If the display reads either "TOO COOL" or "TOO HOT" the upper platen will not go into "STANDBY".

2. PRESS the GREEN ("CANCEL/RAISE") and the BLACK ("STANDBY") buttons at the same time. As soon as the upper platen moves down, release both buttons and press the BLACK ("STANDBY") button again, (within 5 seconds), from the start of a cook cycle, the display will read "STANDBY MODE" alternating with the "MENU ITEM".

EXIT the Standby Mode:

1. PRESS the GREEN ("CANCEL/RAISE") button. The upper platen will raise and the display will read "CANCEL" with an audible alarm.

Standby Alarm (Version 6.20 and higher)

An audible alarm called the "Standby Alarm" has been added to version 6.20 EPROM chip. This alarm, when enabled to "YES" (See Programming - System Setup) will sound if the grill has been idle for 300 seconds (5 minutes) signaling the operator to put the grill into the Standby Mode.

The alarm is INACTIVE if the "Standby Alarm" feature under SYSTEM SETUP is enabled to "NO".

To Display the Current Temperature

1. PRESS the "TEMP" button and repeat for each zone to be displayed.

1st press - CENTER UPPER PLATEN

2nd press - REAR LOWER ZONE

3rd press - CENTER LOWER ZONE

4th press - FRONT LOWER ZONE

NOTE: The temperatures may be displayed at any time, including during a cooking cycle.

To display all temperature zones at the same time, press the "TEMP" button one, (1), time, then the "PROG" button five, (5), times.

To View Settings for a Menu Item:

1. With the required menu displayed, PRESS the "UP ARROW" button ().
2. PRESSING the "UP ARROW" button () repeatedly will cycle through and display that menu's function time(s), set temperature(s) and the gap setting (if applicable).

NOTE: The display will return to the menu (menu name) after five (5) seconds if the "UP ARROW" button () has not been pressed.

To Reset Factory Defaults

NOTE: All settings on all menus will revert to factory defaults. It is recommended that all current settings be recorded on paper prior to reloading the factory default settings.

1. PRESS and HOLD the "PROG" button for five, (5), seconds. (Display will flash GC450 and the program version number.
2. PRESS and HOLD the "UP ARROW" button () for twenty, (10), seconds, "RELOAD DEFAULTS" will be displayed.
3. PRESS the "RIGHT ARROW" button (®) to reload. (Display will read "RELOADING DEFAULTS").
4. PRESS the "RIGHT ARROW" (®) to return to the normal OPERATING MODE.

NOTE: Pressing any other button will cancel the RELOAD DEFAULTS request.

NORMAL OPERATING MODES

To Clean the Grill:

1. PRESS the "MENU" button to obtain the menu "CLEAN MODE." (The controls will maintain the proper cleaning temperature).
2. "READY TO CLEAN" will be displayed when the grill is at the proper cleaning temperature and an audible alarm will sound. Press the "MENU" button to display "OFF." The "OFF" position on the controllers allows the operator to raise and lower the upper platens to alternate positions for proper cleaning of the side and rear edges of the platens.
3. When cleaning is completed, you may turn the "MASTER POWER" (rocker) switch off.

NOTE: Be sure to check upper platen safety pin is disengaged (pulled out) prior to pushing grill back under grill.

Breakfast to Lunch Transition (Transition Cooking)

Approximately 30 minutes before changing to the lunch menu, perform the following:

1. PRESS the "TEMP" button (to display the upper platen temperature).
2. Press the "UP ARROW" (↑) button.
3. The upper platen indicator will light (AMBER) and maintain the normal operating (set) temperature.

Multi-Stage Cooking

If you have version 7.30 EPROM chip software, your controller is equipped with the new Multi-stage cooking feature.

With Multi-Stage cooking, the product being cooked is cooked using multiple gap settings for a selected period of time.

For example, during 4:1 cooking, the platen would normally gap at a gap setting of .416 (Four-hundred and sixteen thousandths) for the entire length of the cook cycle.

With multi stage cooking, the platen may gap at the beginning of the cook cycle for .416 for only 20 seconds. At the interval of 21 seconds, the gap may change to .400 for another 25 seconds.

At the 46 second interval (in the remove time), the platen may regap at .420.

NOTE: the above mentioned example is IS NOT the McDonalds multi gap formula for 4:1 cooking.

All of the "CLAM" menu items programmed in this 7.30 eprom chip have options to cook using the multi-stage gap feature.

Currently, 10:1 - CLAM, and 4:1 - CLAM are the only menu items with a factory default program with multiple gaps. Please see table to right showing additional stages for these products.

| PRODUCT | FUNCTION | TIME | GAP (MULTI ACTIVE) | TOAST BUNS TIME | TOP TEMP | BOTTOM TEMP |
|-------------|-----------|------|--------------------|-----------------|----------------|----------------|
| 10:1 - CLAM | REMOVE IN | 37 | .265 | 0 | 425°F 218°C | 350°F 177°C |
| | STAGE #1 | 5 | .245 | | | |
| | STAGE #2 | 0 | 0 | | | |
| | STAGE #3 | 0 | 0 | | | |
| 4:1 | REMOVE IN | 107 | .425 | 0 | 425°F 277°C | 350°F 177°C |
| | STAGE #1 | 10 | .400 | | | |
| | STAGE #2 | 0 | 0 | | | |
| | STAGE #3 | 0 | 0 | | | |

THE TABLE ABOVE REPRESENTS THE 2 MENU ITEMS THAT HAVE A FACTORY DEFAULT SETTING FOR MULTI STAGE COOKING.

*** ONLY AVAILABLE IN 7.XX ***

FOR INFORMATION REGARDING ALL MENU ITEMS, AND THEIR DETAILED LISTING OF FUNCTIONS, SEE "CONTROLLER MENU ITEMS"

PROGRAM LOGIC CHART

The diagram below is a graphical representation of the control's menu structure in the program modes. The following pages detail the various programming procedures. After you become more familiar with these procedures, this diagram will serve as a quick reference to the program functions and the key sequences needed to access them.

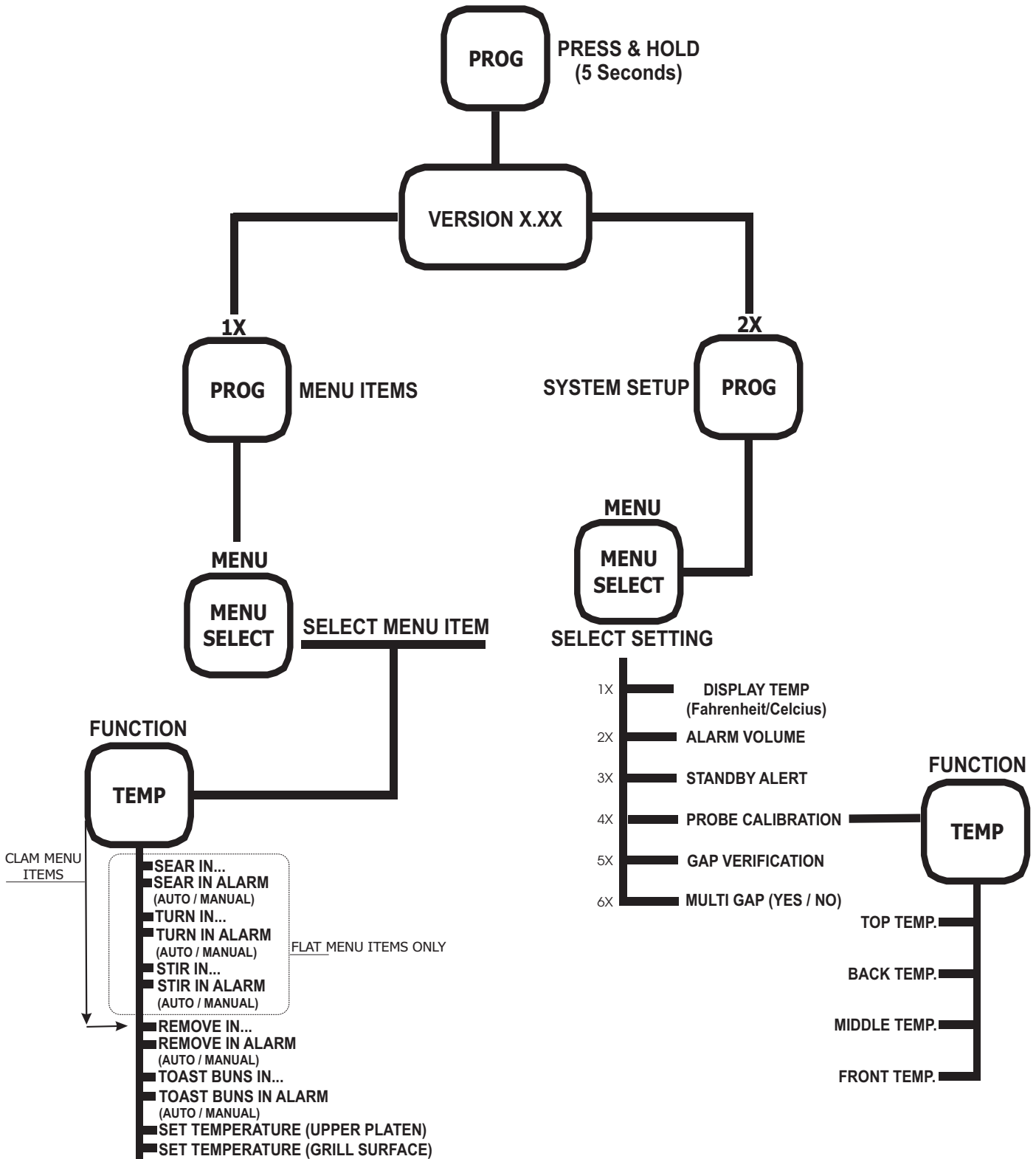

PROGRAMMING

SYSTEM SETUP

To Display Temperatures in F or C

1. **PRESS** and **HOLD** the “**PROG**” button for **five, (5), seconds**. (Display will flash GC450 and the program version number).
2. **PRESS** the “**PROG**” button **twice** to display “**SYSTEM SETUP**”.
3. **PRESS** the “**MENU**” button to display “**DISPLAY TEMP. IN : °F/°C**”.
4. **PRESS** the “**UP ARROW**” button (↑) to change °F or °C.
5. **PRESS** the “**PROG**” button to display “**SYSTEM SETUP**”.
6. **PRESS** the “**RIGHT ARROW**” button (→) to **return to the normal OPERATING MODE**.

To Change the Speaker Volume (High / Low)

1. **PRESS** and **HOLD** the “**PROG**” button for **five, (5), seconds**. (Display will flash GC450 and the program version number).
2. **PRESS** the “**PROG**” button **twice** to display “**SYSTEM SETUP**”.
3. **PRESS** the “**MENU**” button to display “**ALARM VOLUME**”.
4. **PRESS** the “**UP ARROW**” button (↑) to **change (HIGH/LOW)**.
5. **PRESS** the “**PROG**” button to display “**SYSTEM SETUP**”.
6. **PRESS** the “**RIGHT ARROW**” button (→) to **return to the normal OPERATING MODE**.

To Change the Gap Calibration

1. **PRESS** and **HOLD** the “**PROG**” button for **five, (5), seconds**. (Display will flash GC450 and the program version number).
2. **PRESS** the “**PROG**” button **twice** to display “**SYSTEM SETUP**”.
3. **PRESS** and **HOLD** the “**UP ARROW**” (↑) button for **ten, (10), seconds**, “**GAP CALIBRATION**” will be displayed.
4. **PRESS** the “**UP ARROW**” button (↑) again, the “**+**” (**PLUS**) button **to increase** the value **OR** the “**RIGHT ARROW**” button (→), “**-**” (**MINUS**) **to decrease** the value.
5. **PRESS** the “**PROG**” button to display “**SYSTEM SETUP**”.
6. **PRESS** the “**RIGHT ARROW**” button (→), **to return to the normal OPERATING MODE**.

To Enable / Disable Start Delay

1. **PRESS** and **HOLD** the “**PROG**” button for **five, (5), seconds**. (Display will flash GC450 and the program version number).
2. **PRESS** the “**PROG**” button **twice** to display “**SYSTEM SETUP**”.
3. **PRESS** and **HOLD** the “**UP ARROW**”(↑) button for **ten, (10), seconds**, “**GAP CALIBRATION**” will be displayed.
4. **PRESS** the “**MENU**” button. The hold feature will display “**OFF**”.
5. **HOLD** the “**RIGHT ARROW**” (→) for **ten, (10), seconds**, the “**OFF WILL FLASH**”.
6. **PRESS** the “**UP ARROW**” (↑) to change the safety (ON/OFF).
7. **PRESS** the “**PROG**” button to display “**SYSTEM SETUP**”.
8. **PRESS** the “**RIGHT ARROW**” button (→) to **return to the normal OPERATING MODE**.

PROGRAMMING

SYSTEM SETUP

To Change Start Delay Timer

1. **PRESS** and **HOLD** the "PROG" button for **five, (5), seconds**. (Display will flash GC450 and the program version number).
2. **PRESS** the "PROG" button **twice** to display "SYSTEM SETUP".
3. **PRESS** and **HOLD** the "UP ARROW"(↑) button for **ten, (10), seconds**, "GAP CALIBRATION" will be displayed.
4. **PRESS** the "MENU" button. The hold feature will display "OFF".
5. **HOLD** the "RIGHT ARROW" (→) for ten, (10), seconds, the "(ON / OFF) WILL FLASH".
6. **PRESS** the "UP ARROW" (↑) to change the safety (ON/OFF).
7. **PRESS** the "FUNCTION" button to display "DELAY TIME:"
8. **PRESS** the "UP ARROW" (↑) to change the delay time seconds in increments of .5 seconds.
9. **PRESS** the "PROG" button to display "SYSTEM SETUP".
10. **PRESS** the "RIGHT ARROW" button (→) to return to the normal **OPERATING MODE**.

To Change the Standby Alert Feature - EPROM Chip Ver. 6.20 and higher

1. **PRESS** and **HOLD** the "PROG" button for **five, (5), seconds**. (Display will flash GC450 and the program version number).
2. **PRESS** the "PROG" button **twice** to display "SYSTEM SETUP".
3. **PRESS** the "MENU" button until "STANDBY ALERT (YES/NO)".
4. **PRESS** the "UP ARROW" button (↑) to **change (YES/NO)**.
5. **PRESS** the "PROG" button to display "SYSTEM SETUP".
6. **PRESS** the "RIGHT ARROW" button (→) to **return to the normal OPERATING MODE**.

To Enable / Disable Multi-Stage Cooking - EPROM Chip Ver. 7.XX and higher

1. **PRESS** and **HOLD** the "PROG" button for **five, (5), seconds**. (Display will flash GC450 and the program version number).
2. **PRESS** the "PROG" button **twice** to display "SYSTEM SETUP".
3. **PRESS** the "MENU" button until "MULTI GAP CLAM" is displayed.
4. **PRESS** and **HOLD** the "RIGHT ARROW" button (→) until the (YES/NO) begins to flash.
5. **PRESS** the "UP ARROW" button (↑) to change "YES" to "NO" or "NO" to "YES".
6. **PRESS** the "PROG" button
7. **PRESS** the "RIGHT ARROW" button (→) to **return to the normal OPERATING MODE**.

NOTE: To Determine your version EPROM chip. **PRESS** and **HOLD** the PROG button for approximately 5 seconds. The controller will flash "GC450 - V. X.XX". Eprom Chips are available by calling your local factory authorized service center.

PROGRAMMING

MENU ITEMS

To Add or Delete a Menu Item

1. **PRESS** and **HOLD** the “**PROG**” button for **five, 5 seconds**. (Display will flash GC450 and the program version number).
2. **PRESS** the “**PROG**” button **one time** to display “**MENU ITEMS**”.
3. **PRESS** the “**MENU**” button to display the menu you want to add/delete.
4. **PRESS** the “**UP ARROW**” button (↑) to change “**Y**” or “**N**”.
5. **PRESS** the “**PROG**” button to display “**MENU ITEMS**”.
6. **PRESS** the “**RIGHT ARROW**” button (→) to return to the normal **OPERATING MODE**.

To Change the Remove Time

1. **PRESS** and **HOLD** the “**PROG**” button for **five, 5 seconds**. (Display will flash GC450 and the program version number).
2. **PRESS** the “**PROG**” button **one time** to display “**MENU ITEMS**”.
3. **PRESS** the “**MENU**” button to display the menu you want to adjust.
4. **PRESS** the “**FUNCTION**” button **one time** to display “**REMOVE IN XXX**”.
5. **PRESS** the “**UP ARROW**” button (↑) to change the value of the flashing digit.
6. **PRESS** the “**RIGHT ARROW**” button (→) to advance the cursor to the right for changing its value.
7. **PRESS** the “**PROG**” button to display “**MENU ITEMS**”.
8. **PRESS** the “**RIGHT ARROW**” button (→) to return to the normal **OPERATING MODE**.

To Change the Remove Time Alarm (Auto/Manual)

1. **PRESS** and **HOLD** the “**PROG**” button for **five, 5 seconds**. The display will flash the version number.
2. **PRESS** the “**PROG**” button **one time** to display “**MENU ITEMS**”.
3. **PRESS** the “**MENU**” button to display the menu you want to adjust.
4. **PRESS** the “**FUNCTION**” button **until** “**REMOVE IN XXX**” is displayed.
5. **PRESS** the “**FUNCTION**” button **1X**. Controller will display “**ALARM (AUTO / MANUAL)**”.
6. **PRESS** the “**UP ARROW**” button (↑) to change the setting (**AUTO/MANUAL**).
7. **PRESS** the “**PROG**” button to display “**MENU ITEMS**”.
8. **PRESS** the “**RIGHT ARROW**” button (→) to return to the normal **OPERATING MODE**.

PROGRAMMING

To Change the Sear Time

The following procedure IS ONLY AVAILABLE and can only be changed in FLAT MENU ITEMS.

1. **PRESS** and **HOLD** the “**PROG**” button for **five, 5 seconds**. The display will flash the version number.
2. **PRESS** the “**PROG**” button **one time** to display “**MENU ITEMS**”.
3. **PRESS** the “**MENU**” button to display the menu you want to adjust.
4. **PRESS** the “**FUNCTION**” button **until** “**SEAR IN XXX**” is displayed on the controller.

NOTE: IF SEAR TIME IS NOT DISPLAYED ON THE CONTROLLER, ENSURE THAT THE CURRENT PRODUCT SELECTED IS A FLAT MENU ITEM.

5. **PRESS** the “**UP ARROW**” button (↑) to change the value of the flashing digit.
6. **PRESS** the “**RIGHT ARROW**” button (→) to advance the cursor to the right for changing its value.
7. **PRESS** the “**PROG**” button to display “**MENU ITEMS**”.
8. **PRESS** the “**RIGHT ARROW**” button (→) to return to the normal **OPERATING MODE**.

To Change the Sear Time Alarm (Auto/Manual)

The following procedure IS ONLY AVAILABLE and can only be changed in FLAT MENU ITEMS.

1. **PRESS** and **HOLD** the “**PROG**” button for **five, 5 seconds**. The display will flash the version number.
2. **PRESS** the “**PROG**” button **one time** to display “**MENU ITEMS**”.
3. **PRESS** the “**MENU**” button to display the menu you want to adjust.
4. **PRESS** the “**FUNCTION**” button **until** “**SEAR IN XXX**” is displayed.

NOTE: IF SEAR IN IS NOT DISPLAYED ON THE CONTROLLER, ENSURE THAT THE CURRENT PRODUCT SELECTED IS A FLAT MENU ITEM

5. **PRESS** the “**FUNCTION**” button 1X. Controller will display “**ALARM (AUTO / MANUAL)**”.

6. **PRESS** the “**UP ARROW**” button (↑) to change the setting (**AUTO/MANUAL**).

7. **PRESS** the “**PROG**” button to display “**MENU ITEMS**”.

8. **PRESS** the “**RIGHT ARROW**” button (→) to return to the normal **OPERATING MODE**.

To Change the Toast Buns Time

1. **PRESS** and **HOLD** the “**PROG**” button for **five, 5 seconds**. The display will flash the version number.

2. **PRESS** the “**PROG**” button **one time** to display “**MENU ITEMS**”.

3. **PRESS** the “**MENU**” button to display the menu you want to adjust.

4. **PRESS** the “**FUNCTION**” button **until** “**TOAST BUNS IN XXX**” is displayed.

5. **PRESS** the “**UP ARROW**” button (↑) to change the value of the flashing digit.

6. **PRESS** the “**RIGHT ARROW**” button (→) to advance the cursor to the right for changing its value.

7. **PRESS** the “**PROG**” button to display “**MENU ITEMS**”.

8. **PRESS** the “**RIGHT ARROW**” button (→) to return to the normal **OPERATING MODE**.

To Change the Toast Buns Alarm (Auto/Manual)

1. **PRESS** and **HOLD** the “**PROG**” button for **five, 5 seconds**. The display will flash the version number.

2. **PRESS** the “**PROG**” button **one time** to display “**MENU ITEMS**”.

3. **PRESS** the “**MENU**” button to display the menu you want to adjust.

4. **PRESS** the “**FUNCTION**” button **until** “**TOAST BUNS IN XXX**” is displayed.

5. **PRESS** the “**FUNCTION**” button 1X until “**ALARM**” is displayed.

6. **PRESS** the “**UP ARROW**” button (↑) to change the setting (**AUTO/MANUAL**).

7. **PRESS** the “**PROG**” button to display “**MENU**”.

PROGRAMMING

MENU ITEMS

ITEMS”.

8. **PRESS** the “**RIGHT ARROW**” button (→) to return to the normal **OPERATING MODE**.

To Change Turn Time

The following procedure IS ONLY AVAILABLE and can only be changed in FLAT MENU ITEMS.

1. **PRESS** and **HOLD** the “**PROG**” button for **five, 5 seconds**. The display will flash the version number.
2. **PRESS** the “**PROG**” button **one time** to display “**MENU ITEMS**”.
3. **PRESS** the “**MENU**” button to display the menu you want to adjust.
4. **PRESS** the “**FUNCTION**” button **until** “**TURN IN XXX**” is displayed on the controller.

NOTE: IF TURN TIME IS NOT DISPLAYED ON THE CONTROLLER, ENSURE THAT THE CURRENT PRODUCT SELECTED IS A FLAT MENU ITEM.

5. **PRESS** the “**UP ARROW**” button (↑) to change the value of the flashing digit.
6. **PRESS** the “**RIGHT ARROW**” button (→) to advance the cursor to the right for changing its value.
7. **PRESS** the “**PROG**” button to display “**MENU ITEMS**”.
8. **PRESS** the “**RIGHT ARROW**” button (→) to return to the normal **OPERATING MODE**.

To Change Turn In Alarm (Auto / Manual)

The following procedure IS ONLY AVAILABLE and can only be changed in FLAT MENU ITEMS.

1. **PRESS** and **HOLD** the “**PROG**” button for **five, 5 seconds**. The display will flash the version number.
2. **PRESS** the “**PROG**” button **one time** to display “**MENU ITEMS**”.
3. **PRESS** the “**MENU**” button to display the menu you want to adjust.

4. **PRESS** the “**FUNCTION**” button **until** “**TURN IN XXX**” is displayed.

NOTE: IF TURN IN IS NOT DISPLAYED ON THE CONTROLLER, ENSURE THAT THE CURRENT PRODUCT SELECTED IS A FLAT MENU ITEM

5. **PRESS** the “**FUNCTION**” button 1X. Controller will display “**ALARM (AUTO / MANUAL)**”.
6. **PRESS** the “**UP ARROW**” button (↑) to change the setting (**AUTO/MANUAL**).
7. **PRESS** the “**PROG**” button to display “**MENU ITEMS**”.
8. **PRESS** the “**RIGHT ARROW**” button (→) to return to the normal **OPERATING MODE**.

To Change the grill surface set temperature

1. **PRESS** and **HOLD** the “**PROG**” button for **five, 5 seconds**. (Display will flash GC450 and the program version number).
2. **PRESS** the “**PROG**” button **one time** to display “**MENU ITEMS**”.
3. **PRESS** the “**MENU**” button to display the menu you want to adjust.
4. **PRESS** the “**FUNCTION**” button **three times** to display “**TOP TEMP**”.
5. **PRESS** the “**UP ARROW**” button (↑) to change the value of the flashing digit.
6. **PRESS** the “**RIGHT ARROW**” button (→) to advance the cursor to the right for changing its value.
7. **PRESS** the “**PROG**” button to display “**MENU ITEMS**”.
8. **PRESS** the “**RIGHT ARROW**” button (→) to return to the normal **OPERATING MODE**.

PROGRAMMING

MENU ITEMS

To Change the upper platen set temperature

1. **PRESS** and **HOLD** the “**PROG**” button for **five, 5 seconds**. (Display will flash GC450 and the program version number).
2. **PRESS** the “**PROG**” button **one time** to display “**MENU ITEMS**”.
3. **PRESS** the “**MENU**” button to display the menu you want to adjust.
4. **PRESS** the “**FUNCTION**” button **four times** to display “**BOTTOM TEMP XXX**”
5. **PRESS** the “**UP ARROW**” button (↑) to change the value of the flashing digit.
6. **PRESS** the “**RIGHT ARROW**” button (→) to advance the cursor to the right for changing its value.
7. **PRESS** the “**PROG**” button to display “**MENU ITEMS**”.
8. **PRESS** the “**RIGHT ARROW**” button(→) to return to the normal **OPERATING MODE**.

To Enable High Limit Test - GRILL SURFACE (Chip V. 3.52 and 4.0* ONLY)

1. **PRESS** and **HOLD** the “**PROG**” button for **five, 5 seconds**. (Display will flash GC450 and the program version number).
2. **PRESS** the “**PROG**” button **one time** to display “**MENU ITEMS**”.
3. **PRESS** the “**MENU**” button to display “**HIGH LIMIT GRILL**”.
4. **PRESS** the “**UP ARROW**” button (↑) to change “**Y**” or “**N**”.
5. **PRESS** the “**PROG**” button to display “**MENU ITEMS**”.
6. **PRESS** the “**RIGHT ARROW**” button (→) to return to the normal **OPERATING MODE**.

To Enable High Limit Test - PLATEN (Chip V. 3.52 and 4.0* ONLY)

1. **PRESS** and **HOLD** the “**PROG**” button for **five, 5 seconds**. (Display will flash GC450 and the program version number).
2. **PRESS** the “**PROG**” button **one time** to display “**MENU ITEMS**”.
3. **PRESS** the **MENU** button to display “**HIGH LIMIT PLATEN**”.
4. **PRESS** the **UP ARROW** (↑) to change “**Y**” to “**N**” or “**N**” to “**Y**”.
5. **PRESS** the **PROG** button to display “**MENU ITEMS**”.
6. **PRESS** the **RIGHT ARROW** button (→) to return to the normal operating mode.

PROGRAMMING

MENU ITEMS

TO ADD / PROGRAM NEW MENU ITEMS

To Add / Program an [Option Menu - CLAM]

1. **PRESS** and **HOLD** the “**PROG**” button for **five, (5), seconds**. (Display will flash GC450 and the program version number).
2. **PRESS** the “**PROG**” button **twice** to display “**SYSTEM SETUP**.”
3. **PRESS** and **HOLD** the “**UP ARROW**” button (↑) for **ten (10) seconds**, “**GAP CALIBRATION**” will be displayed.
4. **PRESS** the “**PROG**” button **twice** to display “**MENU ITEMS**.”
5. **PRESS** the “**MENU**” button to display “**OPTIONAL MENU (1)(2)(3) Clam**”.
6. **PRESS** the “**UP ARROW**” button (↑) to change “**Y/N**”.
7. **PRESS** the “**FUNCTION**” button to obtain “**REMOVE IN XXX**”.
8. **PRESS** the “**UP ARROW**” button (↑) to **obtain the desired number (0 - 9)**.
9. **PRESS** the “**RIGHT ARROW**” button (→) to **move the cursor**, (blinking digit), to the required digit position.
10. **PRESS** the “**FUNCTION**” button to display “**ALARM**”.
11. **PRESS** the “**UP ARROW**” button (↑) to change the setting (**AUTO/MANUAL**).
12. **PRESS** the “**FUNCTION**” button to display “**TOP TEMP**”. Top Temp. Default = OFF.
13. **PRESS** the “**UP ARROW**” button (↑) to change the value of the flashing digit.
14. **PRESS** the “**RIGHT ARROW**” button (→) to advance the cursor to the right for changing its value.
15. **PRESS** the “**FUNCTION**” button to display “**BOTTOM TEMP XXX**”. Bottom Temp. Default = OFF.
16. **PRESS** the “**UP ARROW**” button (↑) to change the value of the flashing digit.
17. **PRESS** the “**RIGHT ARROW**” button (→) to advance the cursor to the right for changing its value.
18. **PRESS** the “**FUNCTION**” button to obtain “**GAP SETTING**”.
19. **PRESS** the “**UP ARROW**” button (↑) to change the value of the flashing digit.
20. **PRESS** the “**RIGHT ARROW**” button (→) to advance the cursor to the right for changing its value.
21. **PRESS** the “**FUNCTION**” button to obtain display “**OPTIONAL MENU CLAM**”. To Label the New menu:
22. **PRESS** the “**UP ARROW**” button (↑) to change the value of the flashing digit.
23. **PRESS** the “**RIGHT ARROW**” button (→) to advance the cursor to the right for changing its value. (Alpha-numeric capabilities).
24. **PRESS** the “**PROG**” button to display “**MENU ITEMS**”.
25. **PRESS** the “**RIGHT ARROW**” button (→) to return to the normal **OPERATING MODE**.

PROGRAMMING

MENU ITEMS

To Add / Program an [OPTION MENU - FLAT]

- PRESS** and **HOLD** the “**PROG**” button for **five, (5), seconds**. (Display will flash GC450 and the program version number).
- PRESS** the “**PROG**” button **once** to display “**MENU ITEMS.**”
- PRESS** the “**MENU**” button to display “**OPTIONAL MENU (1)(2)(3) Flat.**”
- PRESS** the “**UP ARROW**” button (↑) to change “**Y/N.**”
- PRESS** the “**FUNCTION**” button to obtain “**SEAR IN XXX.**”
- PRESS** the “**UP ARROW**” button (↑) to obtain the desired number (0 - 9).
- PRESS** the “**RIGHT ARROW**” button (→) to move the cursor, (blinking digit), to the required digit position.
- PRESS** the “**FUNCTION**” button to display “**ALARM.**”
- PRESS** the “**UP ARROW**” button (↑) to change the setting (**AUTO/MANUAL**).
- PRESS** the “**FUNCTION**” button to obtain “**TURN IN XXX.**”
- PRESS** the “**UP ARROW**” button (↑) to obtain the desired number (0 - 9).
- PRESS** the “**RIGHT ARROW**” button (→) to move the cursor, (blinking digit), to the required digit position.
- PRESS** the “**FUNCTION**” button to display “**ALARM.**”
- PRESS** the “**UP ARROW**” button (↑) to change the setting (**AUTO/MANUAL**).
- PRESS** the “**FUNCTION**” button to display “**REMOVE IN.**”
- PRESS** the “**UP ARROW**” button (↑) to obtain the desired number (0 - 9).
- PRESS** the “**RIGHT ARROW**” button (→) to move the cursor, (blinking digit), to the required digit position.
- PRESS** the “**FUNCTION**” button to display “**ALARM.**”
- PRESS** the “**UP ARROW**” button (↑) to change the setting (**AUTO/MANUAL**).
- PRESS** the “**FUNCTION**” button to display “**BOTTOM TEMP XXX.**” Bottom Temp. Default = OFF.
- Press** the “**UP ARROW**” button (↑) to change the value of the flashing digit.
- PRESS** the “**RIGHT ARROW**” button (→) to advance the cursor to the right for changing its value.
- PRESS** the “**FUNCTION**” button to obtain display “**OPTIONAL MENU FLAT.**” To Label the New menu:
- PRESS** the “**UP ARROW**” button (↑) to change the value of the flashing digit.
- PRESS** the “**RIGHT ARROW**” button (→) to advance the cursor to the right for changing its value. (Alphanumeric capabilities).
- PRESS** the “**PROG**” button to display “**MENU ITEMS.**”
- PRESS** the “**RIGHT ARROW**” button (→) to return to the normal **OPERATING MODE.**

PROBE CALIBRATION

MWE-9501, MWEH-9501 (FULL SIZE & HALF SIZE UNITS WITH 4 ZONES PER HALF)

THIS CALIBRATION PROCESS SHOULD BE DONE AT LEAST ONCE EVERY 2 WEEKS

Model MWE-9501, MWEH-9501

Bi-Weekly Calibration of Grill Temperature Zones

Tools: Digital Pyrometer with Surface Probe

Warning: PERSONAL INJURY FROM BURNS MAY RESULT WHEN COMING IN CONTACT WITH HOT COOKING SURFACES.

NOTE: Calibration of grills is done with release material sheets "OFF".

PLEASE READ THESE INSTRUCTIONS FULLY and note some important items regarding the 7.** Eprom Chip.

1. The upper platen and lower grill plate should be at operating temperatures to perform this calibration procedure. Press the "MENU" button to select a "CLAM" operation and allow the grill to reach the set temperature and stabilize, (approximately 30 minutes).
2. Press and hold the "PROG" button for 5 seconds to enter the program mode, then press "PROG" button (2) times to access the "SYSTEM SETUP".
3. Under "SYSTEM SETUP", press the "MENU" button until "PROBE CALIBRATION" is displayed on the controller.
4. Press the "FUNCTION" button to display the first zone to be calibrated. The first zone displayed is "TOP TEMP - XXX". The zones are displayed in order of TOP, BACK, MIDDLE, and FRONT.

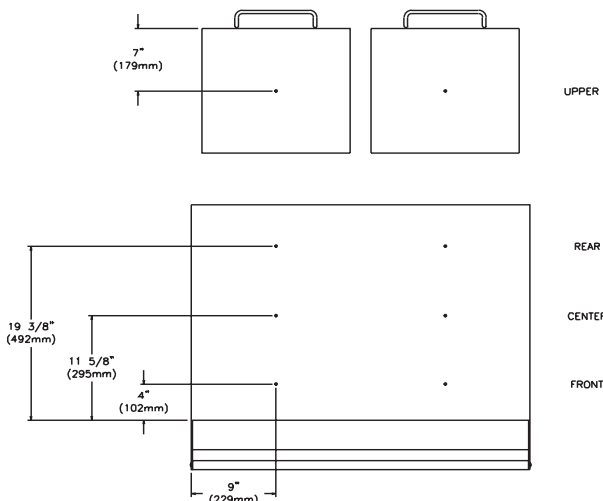
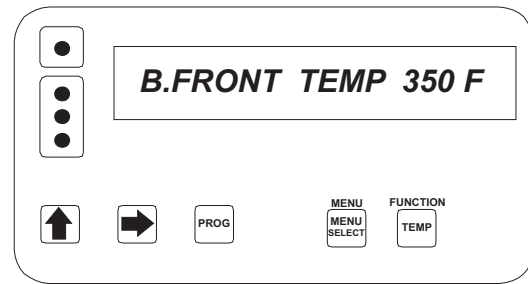

Figure 3 - FULL size electric thermocouple locations



The grill's thermocouple probes are located front to rear, as shown in Figure 3, on each half of the lower grill plate in the center of the cooking zone. Each upper platen has one thermocouple in the center.

5. Select a heat zone display, and then place the surface probe of the digital pyrometer directly on the grill at the same heat zone.
6. Allow at least 5 seconds for the pyrometer to respond and stabilize. Note the temperature on the pyrometer.

NOTE: Eprom Chip Version 7.** has a special feature for Probe Calibration. To ensure that the calibration is done correctly, and at the best time, the controller has a special alarm that will sound when the grill is ready for calibration. If the alarm is not sounding, then the controller will NOT allow the operator to calibrate the grill. It is important to wait until the alarm sounds before any adjustment of temperature is attempted.

7. If the temperature on the grill control display does not match the temperature on the pyrometer, adjust the temperature on the grill control accordingly. The "UP ARROW" button will increase the displayed temperature in one, (1) degree increments. The "RIGHT ARROW" button will decrease the displayed temperature in one, (1), degree increments.
8. Press the "FUNCTION" button to select the next heat zone.
9. Move the pyrometer's surface probe to the newly selected heat zone and repeat steps 6 and 7 above.
10. Repeat the procedure for each of the heat zones.
11. Continue to cycle through each heat zone repeatedly until all temperatures are within 1 degree.
12. Exit the program mode by pressing the "PROG" button, then the "RIGHT ARROW" button. This will return the grill to the clam mode originally chosen.

PROBE CALIBRATION

MWEF-9501, MWEFH-9501 (FULL SIZE & HALF SIZE FLAT UNITS WITH 3 ZONES PER HALF)

THIS CALIBRATION PROCESS SHOULD BE DONE AT LEAST ONCE EVERY 2 WEEKS

Model MWEF-9501, MWEHF-9501

Bi-Weekly Calibration of Grill Temperature Zones

Tools: Digital Pyrometer with Surface Probe

Warning: PERSONAL INJURY FROM BURNS MAY RESULT WHEN COMING IN CONTACT WITH HOT COOKING SURFACES.

NOTE: Calibration of grills is done with release material sheets **“OFF”**.

PLEASE READ THESE INSTRUCTIONS FULLY and note some important items regarding the 7.** Eprom Chip.

1. The upper platens and lower grill plate should be at operating temperatures to perform this calibration procedure. Press the “MENU” button to select a “CLAM” operation and allow the grill to reach the set temperature and stabilize, (approximately 30 minutes).
2. Press and hold the “PROG” button for **5 seconds** to enter the program mode, then press “PROG” button (2) times to access the “SYSTEM SETUP”.
3. Under “SYSTEM SETUP”, press the “MENU” button until “PROBE CALIBRATION” is displayed on the controller.

NOTE: The upper platen is still exists in the controller. Even though the upper platen does not exist, IT IS IMPERATIVE that the upper platen heat zone is calibrated.

IMPORTANT: THE UPPER PLATEN SHOULD BE CALIBRATED UTILIZING THE BACK ZONE AS ITS HEAT ZONE. When the controller reads “Top Temp – XXXF”, your pyrometer should be on the BACK HEAT ZONE. The next zone displayed is “B. Back Temp – XXXF”, your pyrometer WILL REMAIN in the back zone. Proceed to the other heat zones.

4. Press the “FUNCTION” button to display the first zone to be calibrated. The first zone displayed is “TOP TEMP – XXX”. The zones are displayed in order of TOP, BACK, MIDDLE, and FRONT.

The grill’s thermocouple probes are located front to rear, as shown in Figure 4, on each half of the lower grill plate in the center of the cooking zone. Each upper platen has one thermocouple in the center.

5. Select a heat zone display, and then place the surface probe of the digital pyrometer directly on the grill at the same heat zone.
6. Allow at least 5 seconds for the pyrometer to respond and stabilize. Note the temperature on the pyrometer.

NOTE: Eprom Chip Version 7.** has a special feature for Probe Calibration. To ensure that the calibration is done correctly, and at the best time, the controller has a special alarm that will sound when the grill is ready for calibration. If the alarm is not sounding, then the controller will NOT allow the operator to calibrate the grill. It is important to wait until the alarm sounds before any adjustment of temperature is attempted.

7. If the temperature on the grill control display does not match the temperature on the pyrometer, adjust the temperature on the grill control accordingly. The “UP ARROW” button will increase the displayed temperature in one, (1) degree increments. The “RIGHT ARROW” button will decrease the displayed temperature in one, (1), degree Increments.
8. Press the “FUNCTION” button to select the next heat zone.
9. Move the pyrometer’s surface probe to the newly selected heat zone and repeat steps 6 and 7 above.
10. Repeat the procedure for each of the heat zones.
11. Continue to cycle through each heat zone repeatedly until all temperatures are within 1 degree.
12. Exit the program mode by pressing the “PROG” button, then the “RIGHT ARROW” button. This will return the grill to the clam mode originally chosen.

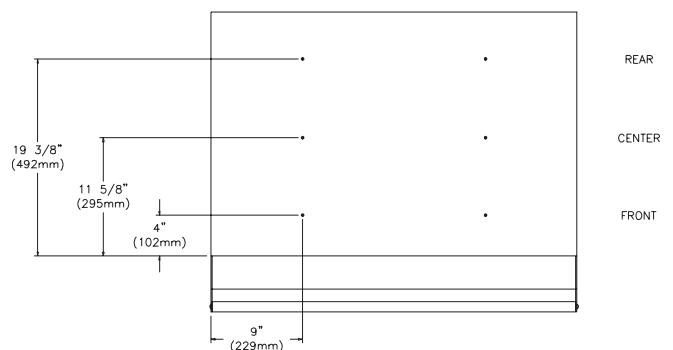

Figure 4 - FULL size electric FLAT thermcouple locations

OPTIONAL ACCESSORIES



Teflon Sheet - 1799301
Teflon Rear Rod - 1851201
Teflon Clip - 1851301



Teflon Rollup Assembly
Left Assy - 1853799
Reight Assy - 1853798

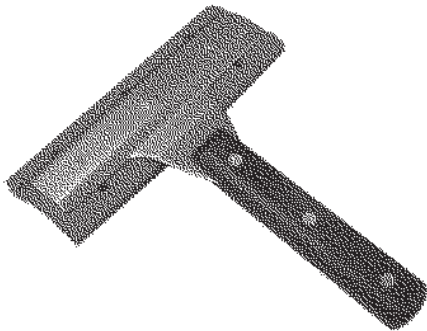

Grill Squeegee - 1858201

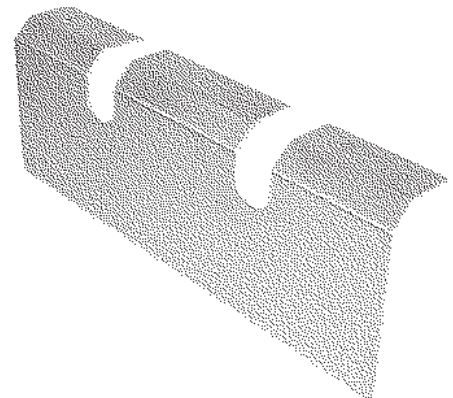

Splash Shield - 1873703

TROUBLESHOOTING

POSSIBLE ERROR MESSAGES

"Probe Open"

An open probe condition has occurred. The controller will turn the heater controlled by the malfunctioning probe OFF. If the open probe condition should correct itself; the control will return to the "IDLE MODE".

"Clam did not go down"

Occurs if the platen does not reach the proper position (GAP SETTING) in 30 seconds. You may cancel the message by pressing the "TEMP" button.

"Upper Platen Stuck"

Occurs when the controller does not get an upper platen setting signal 15 seconds after it starts to raise the platen. In order to return to the "IDLE MODE", the controller must get a upper platen setting signal. You may cancel the message by pressing the "TEMP" button followed by the GREEN ("RAISE") button in order to retry raising the platen.

"Eprom Corrupt"

Displayed at startup when the controller detects a corrupt menu item or when a new version of the software is loaded. To cancel this message, switch the grill "off" and "on" again at the main power switch.

"High Limit"

Occurs when:

1. The Controller senses a zone at 465(F (241(C)

NOTE: The Controller has 2 High Limit tests located at the end of the menu item list. If the test is enabled, that test will heat the zone (Platen, or Grill) to 465(, and the controller will flash "High Limit"

"Motor Overcurrent"

Occurs when:

1. The upper platen has been mechanically resisted the platen will stop.
2. The platen control motor is inoperative. Turn the "MASTER POWER" switch OFF, then ON again.

"Faulty Element / Shorted Probe"

Occurs when the controller does not detect a proper temperature response. Also, the RED LED will light, indicating which element /probe is in error.

NOTE: Should all four, (4), LED's flash RED approximately six, (6), minutes after the unit is turned on, ensure that the main three-phase, (large), power cord is plugged in and the main circuit breaker is ON.

TROUBLESHOOTING

In Store Troubleshooting Guide

| | | |
|---|---|---|
| CONTROLLER DISPLAYS EEPROM CORRUPT | <ol style="list-style-type: none"> 1. NEW VERSION EPROM CHIP? 2. FAULTY EPROM CHIP OR FAULTY CONTROLLER. | <ol style="list-style-type: none"> 1. RE-INITIALIZE UNIT 2. CALL FOR SERVICE |
| PLATEN WILL NOT COME DOWN | <ol style="list-style-type: none"> 1. GRILL HAS NOT REACHED SET TEMPERATURE YET. 2. UPPER PLATEN LOCKING PIN IS ENGAGED 3. PRESS THE GREEN PUSHBUTTON, AND THEN THE BLACK PUSHBUTTON. DO THEY BEEP SEPARATELY? | <ol style="list-style-type: none"> 1. ALLOW GRILL TO REACH SET TEMPERATURE. 2. PULL OUT UPPER PLATEN LOCKING PIN. 3. EITHER YES OR NO, CALL FOR SERVICE |
| CONTROLLER DISPLAYS "TOO HOT" | <ol style="list-style-type: none"> 1. CURRENT SELECTED MENU ITEM REQUIRES A LOWER SET POINT TEMPERATURE THEN THE ONE PREVIOUSLY SELECTED. 2. ONE OR MORE HEAT ZONES HAVE EXCEEDED THE SET POINT TEMPERATURES BY 79°F (27°C). 3. TEMPERATURE IS CONTINUING TO RISE? | <ol style="list-style-type: none"> 1. ALLOW GRILL TO COOL DOWN TO CURRENT MENU ITEMS SET POINT TEMPERATURE. 2. NOTE HEAT ZONE (RED LED LIGHT) AND CALL FOR SERVICE. 3. CALL FOR SERVICE |
| CONTROLLER DISPLAYS "MOTOR OVERCURRENT" | <ol style="list-style-type: none"> 1. TURN MAIN POWER SWITCH OFF, WAIT 5 SECONDS, AND TURN BACK ON TO REINITIALIZE CONTROLLERS. 2. PROBLEM HAPPENS ONLY IN THE MORNING? | <ol style="list-style-type: none"> 1. POSSIBLE FREQUENCY INTERRUPTION. MONITOR FOR REPETITIVE ERROR. 2. POSSIBLE PREVENTATIVE MAINTENANCE NEEDED. 3. CALL FOR SERVICE |
| CONTROLLER DISPLAYS "FAULT ELEMENT / SHORTED PROBE" | <ol style="list-style-type: none"> 1. ARE ALL LED LIGHTS FLASHING RED, BOTH SIDES OR EITHER SIDES? 2. 1 – 3 ZONES FLASHING RED? | <ol style="list-style-type: none"> 1. CHECK TO MAKE SURE THAT ALL POWER CORDS ARE PLUGGED IN PROPERLY. ELECTRIC GRILLS HAVE 3 CORDS. CHECK CIRCUIT BREAKERS. 2. NOTE ZONE AND CALL FOR SERVICE. 3. CALL FOR SERVICE |
| CONTROLLER DISPLAYS "OPEN PROBE" | <ol style="list-style-type: none"> 1. DURING INITIALIZATION? 2. DURING COOKING | <ol style="list-style-type: none"> 1. NOTE ZONE AND CALL FOR SERVICE – POSSIBLE THERMOCOUPLE, INTERFACE BOARD OR CONTROLLER. 2. ZONE(S) BECAME TOO HOT. NOTE ZONE AND CALL FOR SERVICE. POSSIBLE SOLID STATE RELAY, THERMOCOUPLE, THERMOCOUPLE INTERFACE BOARDS, OR CONTROLLER. |

CONTROLLER MENU ITEMS

THE FOLLOWING TABLE LISTS MENU ITEMS DEFAULTED IN THE MAIN CONTROLLER AS NEW. TO REPROGRAM ANY FUNCTION OR FEATURE BELOW, SEE PROGRAMMING.

** THE MENU ITEMS LISTED BELOW ARE FOR EPROM CHIP VERSIONS UP TO 6.20 - FOR EPROM CHIP VERSION 7.XX, PLEASE SEE THE FOLLOWING TABLE FOR MORE INFORMATION **

** TO IDENTIFY YOUR EPROM CHIP, PRESS AND HOLD THE PROG BUTTON THE CONTROLLER **

| Eprom Chip | | | | Menu Item Name | Function (Duty) | Time (Secs) | Set Temp | | Set Temp | | Gap Setting |
|------------|------|----------------------|------|-------------------------|-----------------|-------------|----------|-------|----------|-------|-------------|
| Version # | | | | | | | (F) | (C) | | | |
| 3.01 | 3.52 | 4.00 4.01 4.02 | 6.20 | | | | Lower | Upper | Lower | Upper | |
| YES | YES | YES | YES | OFF (Always first) | NONE | NONE | OFF | OFF | OFF | OFF | .090 |
| | | | | 6.20 Chip & Higher ---> | | | | | | | .083 |
| NO | NO | NO | YES | Preheat | "Ready to Cook" | NONE | 350 | 425 | 177 | 218 | .083 |
| YES | YES | YES | YES | 10:1 - CLAM | Remove | 36 | 350 | 425 | 177 | 218 | .255 |
| | | | | 6.20 Chip & Higher ---> | Toast Buns | 0 | | | | | |
| YES | YES | YES | YES | 4:1 - CLAM | Remove | 104 | 350 | 425 | 177 | 218 | .415 |
| | | | | 6.20 Chip & Higher ---> | Toast Buns | 0 | | | | | |
| YES | YES | YES | NO | Circular Bacon - CLAM | Remove | 88 | 325 | 400 | 163 | 204 | .090 |
| NO | NO | NO | YES | Strip Bacon - CLAM | Remove | 23 | 350 | 425 | 177 | 218 | .090 |
| YES | YES | YES | NO | Sausage - CLAM (THD) | Remove | 48 | 325 | 400 | 163 | 204 | .350 |
| YES | YES | YES | YES | Sausage - CLAM (FRZ) | Remove | 82 | 350 | 425 | 177 | 218 | .350 |
| YES | YES | YES | YES | McRib - CLAM | Remove | 163 | 350 | 425 | 177 | 218 | .530 |
| NO | NO | YES | YES | Steak - CLAM | Remove | 82 | 350 | 425 | 177 | 218 | .415 |
| YES | YES | NO | NO | Grilled Chicken - FLAT | Turn | 115 | 350 | 425 | 177 | 218 | NONE |
| | | | | | Remove | 230 | | | | | |
| NO | NO | YES | YES | Grilled Chicken - FLAT | Turn | 195 | 350 | 425 | 177 | 218 | NONE |
| | | | | | Remove | 410 | | | | | |
| YES | YES | YES | YES | Folded Eggs - FLAT | Remove | 35 | 265 | OFF | 130 | OFF | NONE |
| YES | YES | YES | NO | Canadian Bacon - FLAT | Turn | 10 | 265 | OFF | 130 | OFF | NONE |
| | | | | | Remove | 20 | | | | | |
| YES | YES | YES | YES | Round Eggs | Remove | 150 | 265 | OFF | 130 | OFF | NONE |
| NO | NO | NO | YES | Chick F Bread - FLAT | Remove | 100 | 350 | 425 | 177 | 218 | NONE |
| YES | YES | YES | YES | 10:1 - FLAT | Sear | 20 | 340 | OFF | 171 | OFF | NONE |
| | | | | | Turn | 75 | | | | | |
| | | | | | Remove | 125 | | | | | |
| YES | YES | YES | YES | 4:1 - FLAT | Sear | 20 | 365 | OFF | 185 | OFF | NONE |
| | | | | | Turn | 150 | | | | | |
| | | | | | Remove | 270 | | | | | |
| YES | YES | YES | YES | McRib - FLAT | Turn | 270 | 365 | OFF | 185 | OFF | NONE |
| | | | | | Remove | 390 | | | | | |

CONTROLLER MENU ITEMS

| | | | | | | | | | | | |
|-----|-----|-----|-----|------------------------|----------------------|-----|-----|-----|-----|-----|------|
| YES | YES | YES | NO | Sausage - FLAT (THD) | Turn/Sear | 90 | 365 | OFF | 185 | OFF | NONE |
| | | | | | Remove | 180 | | | | | |
| YES | YES | YES | YES | Sausage - FLAT (FRZ) | Turn/Sear | 150 | 365 | OFF | 185 | OFF | NONE |
| | | | | | Remove | 270 | | | | | |
| YES | YES | YES | YES | Hotcakes - FLAT | Turn | 90 | 365 | OFF | 185 | OFF | NONE |
| | | | | | Remove | 140 | | | | | |
| YES | YES | YES | NO | Ham - FLAT | Turn | 30 | 365 | OFF | 185 | OFF | NONE |
| | | | | | Remove | 60 | | | | | |
| YES | YES | YES | NO | Sausage Burrito - FLAT | Stir | 90 | 365 | OFF | 185 | OFF | NONE |
| | | | | | Remove | 180 | | | | | |
| YES | YES | YES | YES | Option Menu 1 - CLAM | Remove | 0 | 0 | 0 | 0 | 0 | .469 |
| YES | YES | YES | YES | Option Menu 2 - CLAM | Remove | 0 | 0 | 0 | 0 | 0 | .250 |
| YES | YES | NO | YES | Option Menu 3 - CLAM | Remove | 0 | 0 | 0 | 0 | 0 | .250 |
| NO | NO | NO | YES | Option Menu 4 - CLAM | Remove | 0 | 0 | 0 | 0 | 0 | .250 |
| | | | | --- through --- | | | | | | | |
| NO | NO | NO | YES | Option Menu 20 - CLAM | Remove | 0 | 0 | 0 | 0 | 0 | .250 |
| YES | YES | YES | YES | Option Menu 1 - FLAT | Turn/Sear/ Remove | 0 | 0 | 0 | 0 | 0 | NONE |
| YES | YES | NO | YES | Option Menu 2 - FLAT | Turn/Sear/ Remove | 0 | 0 | 0 | 0 | 0 | NONE |
| YES | YES | NO | YES | Option Menu 3 - FLAT | Turn/Sear/ Remove | 0 | 0 | 0 | 0 | 0 | NONE |
| | | | | --- through --- | | | | | | | |
| NO | NO | NO | YES | Option Menu 8 - FLAT | Turn/Sear/ Remove | 0 | 0 | 0 | 0 | 0 | NONE |

CONTROLLER MENU ITEMS (EPROM CHIP VER. 7.XX)

| ITEM | ACTIVE | FUNCTION | TIME | ALARM | GAP (NON-MULTI) | GAP (MULTI) | MUST REMOVE TIME | TOAST BUNS TIME | TOAST BUNS ALARM | TOP TEMP (F) | BOTTOM TEMP (F) |
|------------------|-----------|---------------|------|--------|-----------------|-------------|------------------|-----------------|------------------|--------------|-----------------|
| OFF | YES(ONLY) | NONE | NONE | NONE | 0.09 | 0.09 | NONE | NONE | NONE | OFF | OFF |
| PREHEAT | YES(ONLY) | READY TO COOK | NONE | NONE | 0.09 | 0.09 | NONE | NONE | NONE | 425 | 350 |
| 10:1-CLAM | YES | REMOVE IN | 37 | AUTO | .255 | .265 | 0 | 0 | AUTO | 425 | 350 |
| | | STAGE # 1 | 5 | NONE | --- | .245 | | | | | |
| | | STAGE # 2 | 0 | NONE | --- | 0 | | | | | |
| | | STAGE # 3 | 0 | NONE | --- | 0 | | | | | |
| 4:1-CLAM | YES | REMOVE IN | 107 | AUTO | .415 | .425 | 0 | 0 | AUTO | 425 | 350 |
| | | STAGE # 1 | 10 | NONE | --- | .400 | | | | | |
| | | STAGE # 2 | 0 | NONE | --- | 0 | | | | | |
| | | STAGE # 3 | 0 | NONE | --- | 0 | | | | | |
| STRIP BACON-CLAM | YES | REMOVE IN | 23 | AUTO | .089 | .089 | NONE | NONE | NONE | 425 | 350 |
| | | STAGE # 1 | 0 | NONE | --- | 0 | | | | | |
| | | STAGE # 2 | 0 | NONE | --- | 0 | | | | | |
| | | STAGE # 3 | 0 | NONE | --- | 0 | | | | | |
| SAUSAGE-CLAM FZN | YES | REMOVE IN | 82 | AUTO | .350 | .350 | NONE | NONE | NONE | 425 | 350 |
| | | STAGE # 1 | 0 | NONE | --- | 0 | | | | | |
| | | STAGE # 2 | 0 | NONE | --- | 0 | | | | | |
| | | STAGE # 3 | 0 | NONE | --- | 0 | | | | | |
| McRIB-CLAM | NO | REMOVE IN | 163 | AUTO | .530 | .530 | NONE | NONE | NONE | 425 | 350 |
| | | STAGE # 1 | 0 | NONE | --- | 0 | | | | | |
| | | STAGE # 2 | 0 | NONE | --- | 0 | | | | | |
| | | STAGE # 3 | 0 | NONE | --- | 0 | | | | | |
| STEAK-CLAM | YES | REMOVE IN | 104 | AUTO | .415 | .415 | NONE | NONE | NONE | 425 | 350 |
| | | STAGE # 1 | 0 | NONE | --- | 0 | | | | | |
| | | STAGE # 2 | 0 | NONE | --- | 0 | | | | | |
| | | STAGE # 3 | 0 | NONE | --- | 0 | | | | | |
| GRILL CHICK-FLAT | YES | TURN IN | 195 | MANUAL | --- | --- | NONE | NONE | NONE | 425 | 350 |
| | | REMOVE IN | 410 | AUTO | --- | --- | | | | | |
| FOLDED EGGS-FLAT | YES | REMOVE IN | 35 | AUTO | --- | --- | NONE | NONE | NONE | OFF | 265 |
| ROUND EGGS-FLAT | YES | REMOVE IN | 150 | AUTO | --- | --- | NONE | NONE | NONE | OFF | 265 |
| CHICK F BRD-FLAT | YES | REMOVE IN | 100 | AUTO | --- | --- | NONE | NONE | NONE | 425 | 350 |

CONTROLLER MENU ITEMS (EPROM CHIP VER. 7.XX)

| | | | | | | | | | |
|------------------|----------------|------|--------|------|------|------|------|------|-----|
| 10:1-FLAT | SEAR IN | 20 | MANUAL | --- | --- | NONE | NONE | NONE | 340 |
| | TURN IN | 75 | AUTO | --- | --- | | | OFF | |
| | REMOVE IN | 125 | AUTO | --- | --- | | | | |
| 4:1-FLAT | SEAR IN | 20 | MANUAL | --- | --- | NONE | NONE | NONE | 365 |
| | TURN IN | 150 | AUTO | --- | --- | | | OFF | |
| | REMOVE IN | 270 | AUTO | --- | --- | | | | |
| McRIB-FLAT | TURN IN | 270 | AUTO | --- | --- | NONE | NONE | OFF | 365 |
| | REMOVE IN | 390 | AUTO | --- | --- | | | | |
| | TURN/SEAR IN | 150 | MANUAL | --- | --- | NONE | NONE | OFF | 365 |
| SAUSAGE-FLAT FZN | REMOVE IN | 270 | AUTO | --- | --- | | | OFF | |
| | TURN IN | 90 | AUTO | --- | --- | NONE | NONE | OFF | 365 |
| | REMOVE IN | 140 | AUTO | --- | --- | | | | |
| HOTCAKES-FLAT | REMOVE IN | 0 | AUTO | .469 | .469 | | | | |
| | STAGE # 1 | 0 | NONE | --- | --- | NONE | NONE | OFF | OFF |
| | STAGE # 2 | 0 | NONE | --- | --- | | | | |
| | STAGE # 3 | 0 | NONE | --- | --- | | | | |
| OPT MENU 1-CLAM | REMOVE IN | 0 | AUTO | .250 | .250 | | | | |
| | STAGE # 1 | 0 | NONE | --- | --- | NONE | NONE | OFF | OFF |
| | STAGE # 2 | 0 | NONE | --- | --- | | | | |
| | STAGE # 3 | 0 | NONE | --- | --- | | | | |
| OPT MENU 2-CLAM | SEAR IN | 0 | AUTO | --- | --- | NONE | NONE | | |
| | TURN IN | 0 | AUTO | --- | --- | | | OFF | |
| | REMOVE IN | 0 | AUTO | --- | --- | | | | |
| OPT MENU 7-CLAM | SEAR IN | 0 | AUTO | --- | --- | NONE | NONE | | |
| | TURN IN | 0 | AUTO | --- | --- | | | OFF | |
| | REMOVE IN | 0 | AUTO | --- | --- | | | | |
| OPT MENU 1-FLAT | SEAR IN | 0 | AUTO | --- | --- | NONE | NONE | | |
| | TURN IN | 0 | AUTO | --- | --- | | | OFF | |
| | REMOVE IN | 0 | AUTO | --- | --- | | | | |
| OPT MENU 4-FLAT | SEAR IN | 0 | AUTO | --- | --- | NONE | NONE | | |
| | TURN IN | 0 | AUTO | --- | --- | | | OFF | |
| CLEAN MODE | READY TO CLEAN | NONE | NONE | .090 | .090 | NONE | NONE | 325 | 325 |

TEMPERATURE CONVERSION (F / C)

| C | F | C | F | C | F | C | F | C | F |
|----|-----|----|-----|-----|-----|-----|-----|-----|-----|
| 27 | 80 | 54 | 128 | 80 | 176 | 107 | 224 | 134 | 272 |
| 27 | 81 | 54 | 129 | 80 | 177 | 107 | 225 | 134 | 273 |
| 28 | 82 | 55 | 130 | 81 | 178 | 108 | 226 | 134 | 274 |
| 28 | 83 | 55 | 131 | 81 | 179 | 108 | 227 | 135 | 275 |
| 29 | 84 | 56 | 132 | 82 | 180 | 109 | 228 | 135 | 276 |
| 30 | 85 | 56 | 133 | 83 | 181 | 110 | 229 | 136 | 277 |
| 30 | 86 | 57 | 134 | 83 | 182 | 110 | 230 | 137 | 278 |
| 31 | 87 | 57 | 135 | 84 | 183 | 111 | 231 | 137 | 279 |
| 31 | 88 | 58 | 136 | 84 | 184 | 111 | 232 | 138 | 280 |
| 32 | 89 | 59 | 137 | 85 | 185 | 112 | 233 | 138 | 281 |
| 32 | 90 | 59 | 138 | 85 | 186 | 112 | 234 | 139 | 282 |
| 33 | 91 | 60 | 139 | 86 | 187 | 113 | 235 | 139 | 283 |
| 33 | 92 | 60 | 140 | 86 | 188 | 114 | 236 | 140 | 284 |
| 34 | 93 | 61 | 141 | 87 | 189 | 114 | 237 | 141 | 285 |
| 34 | 94 | 61 | 142 | 88 | 190 | 115 | 238 | 141 | 286 |
| 35 | 95 | 62 | 143 | 88 | 191 | 115 | 239 | 142 | 287 |
| 36 | 96 | 62 | 144 | 89 | 192 | 116 | 240 | 142 | 288 |
| 36 | 97 | 63 | 145 | 89 | 193 | 116 | 241 | 143 | 289 |
| 37 | 98 | 63 | 146 | 90 | 194 | 117 | 242 | 143 | 290 |
| 37 | 99 | 64 | 147 | 90 | 195 | 117 | 243 | 144 | 291 |
| 38 | 100 | 64 | 148 | 91 | 196 | 118 | 244 | 144 | 292 |
| 38 | 101 | 65 | 149 | 91 | 197 | 119 | 245 | 145 | 293 |
| 39 | 102 | 65 | 150 | 92 | 198 | 119 | 246 | 146 | 294 |
| 40 | 103 | 66 | 151 | 93 | 199 | 120 | 247 | 146 | 295 |
| 40 | 104 | 66 | 152 | 94 | 200 | 120 | 248 | 147 | 296 |
| 41 | 105 | 67 | 153 | 94 | 201 | 121 | 249 | 147 | 297 |
| 41 | 106 | 68 | 154 | 94 | 202 | 121 | 250 | 148 | 298 |
| 42 | 107 | 68 | 155 | 95 | 203 | 122 | 251 | 148 | 299 |
| 42 | 108 | 69 | 156 | 95 | 204 | 122 | 252 | 149 | 300 |
| 43 | 109 | 70 | 157 | 96 | 205 | 123 | 253 | 149 | 301 |
| 43 | 110 | 70 | 158 | 97 | 206 | 124 | 254 | 150 | 302 |
| 44 | 111 | 71 | 159 | 97 | 207 | 124 | 255 | 151 | 303 |
| 44 | 112 | 71 | 160 | 98 | 208 | 125 | 256 | 151 | 304 |
| 45 | 113 | 72 | 161 | 98 | 209 | 125 | 257 | 152 | 305 |
| 45 | 114 | 72 | 162 | 99 | 210 | 126 | 258 | 152 | 306 |
| 46 | 115 | 73 | 163 | 99 | 211 | 126 | 259 | 153 | 307 |
| 46 | 116 | 74 | 164 | 100 | 212 | 127 | 260 | 153 | 308 |
| 47 | 117 | 74 | 165 | 101 | 213 | 127 | 261 | 154 | 309 |
| 48 | 118 | 75 | 166 | 101 | 214 | 128 | 262 | 154 | 310 |
| 48 | 119 | 75 | 167 | 102 | 215 | 128 | 263 | 155 | 311 |
| 49 | 120 | 76 | 168 | 102 | 216 | 129 | 264 | 156 | 312 |
| 49 | 121 | 76 | 169 | 103 | 217 | 130 | 265 | 156 | 313 |
| 50 | 122 | 77 | 170 | 103 | 218 | 130 | 266 | 157 | 314 |
| 50 | 123 | 77 | 171 | 104 | 219 | 130 | 267 | 157 | 315 |
| 51 | 124 | 78 | 172 | 105 | 220 | 131 | 268 | 158 | 316 |
| 52 | 125 | 78 | 173 | 105 | 221 | 131 | 269 | 158 | 317 |
| 52 | 126 | 79 | 174 | 106 | 222 | 132 | 270 | 159 | 318 |
| 53 | 127 | 79 | 175 | 106 | 223 | 133 | 271 | 159 | 319 |

TEMPERATURE CONVERSION (F / C)

| C | F | C | F | C | F | C | F | C | F |
|-----|-----|-----|-----|-----|-----|-----|-----|-----|-----|
| 160 | 320 | 187 | 368 | 213 | 416 | 240 | 464 | 267 | 512 |
| 161 | 321 | 187 | 369 | 214 | 417 | 241 | 465 | 267 | 513 |
| 161 | 322 | 188 | 370 | 214 | 418 | 241 | 466 | 268 | 514 |
| 162 | 323 | 188 | 371 | 215 | 419 | 242 | 467 | 268 | 515 |
| 162 | 324 | 189 | 372 | 216 | 420 | 242 | 468 | 269 | 516 |
| 163 | 325 | 189 | 373 | 216 | 421 | 243 | 469 | 269 | 517 |
| 163 | 326 | 190 | 374 | 217 | 422 | 243 | 470 | 270 | 518 |
| 164 | 327 | 191 | 375 | 217 | 423 | 244 | 471 | 271 | 519 |
| 164 | 328 | 191 | 376 | 218 | 424 | 244 | 472 | 271 | 520 |
| 165 | 329 | 192 | 377 | 218 | 425 | 245 | 473 | 272 | 521 |
| 166 | 330 | 192 | 378 | 219 | 426 | 246 | 474 | 272 | 522 |
| 166 | 331 | 193 | 379 | 219 | 427 | 246 | 475 | 273 | 523 |
| 167 | 332 | 193 | 380 | 220 | 428 | 247 | 476 | 273 | 524 |
| 167 | 333 | 194 | 381 | 221 | 429 | 247 | 477 | 274 | 525 |
| 168 | 334 | 194 | 382 | 221 | 430 | 248 | 478 | 274 | 526 |
| 168 | 335 | 195 | 383 | 222 | 431 | 248 | 479 | 275 | 527 |
| 169 | 336 | 196 | 384 | 222 | 432 | 249 | 480 | 276 | 528 |
| 169 | 337 | 196 | 385 | 223 | 433 | 249 | 481 | 276 | 529 |
| 170 | 338 | 197 | 386 | 223 | 434 | 250 | 482 | 277 | 530 |
| 171 | 339 | 197 | 387 | 224 | 435 | 241 | 483 | 277 | 531 |
| 171 | 340 | 198 | 388 | 224 | 436 | 241 | 484 | 278 | 532 |
| 172 | 341 | 198 | 389 | 225 | 437 | 252 | 485 | 278 | 533 |
| 172 | 342 | 199 | 390 | 226 | 438 | 252 | 486 | 279 | 534 |
| 173 | 343 | 199 | 391 | 226 | 439 | 253 | 487 | 279 | 535 |
| 173 | 344 | 200 | 392 | 227 | 440 | 253 | 488 | 280 | 536 |
| 174 | 345 | 201 | 393 | 227 | 441 | 254 | 489 | 281 | 537 |
| 174 | 346 | 201 | 394 | 228 | 442 | 254 | 490 | 281 | 538 |
| 175 | 347 | 202 | 395 | 228 | 443 | 255 | 491 | 282 | 539 |
| 176 | 348 | 202 | 396 | 229 | 444 | 256 | 492 | 282 | 540 |
| 176 | 349 | 203 | 397 | 229 | 445 | 256 | 493 | 283 | 541 |
| 177 | 350 | 203 | 398 | 230 | 446 | 257 | 494 | 283 | 542 |
| 177 | 351 | 204 | 399 | 231 | 447 | 257 | 495 | 284 | 543 |
| 178 | 352 | 204 | 400 | 231 | 448 | 258 | 496 | 284 | 544 |
| 178 | 353 | 205 | 401 | 232 | 449 | 258 | 497 | 285 | 545 |
| 179 | 354 | 206 | 402 | 232 | 450 | 259 | 498 | 285 | 546 |
| 179 | 355 | 206 | 403 | 233 | 451 | 259 | 499 | 286 | 547 |
| 180 | 356 | 207 | 404 | 233 | 452 | 260 | 500 | 287 | 548 |
| 181 | 357 | 207 | 405 | 234 | 453 | 261 | 501 | 287 | 549 |
| 181 | 358 | 208 | 406 | 234 | 454 | 261 | 502 | 288 | 550 |
| 182 | 359 | 208 | 407 | 235 | 455 | 262 | 503 | 288 | 551 |
| 182 | 360 | 209 | 408 | 236 | 456 | 262 | 504 | 289 | 552 |
| 183 | 361 | 209 | 409 | 236 | 457 | 263 | 505 | 290 | 553 |
| 183 | 362 | 210 | 410 | 237 | 458 | 263 | 506 | 290 | 554 |
| 184 | 363 | 211 | 411 | 237 | 459 | 264 | 507 | 291 | 555 |
| 184 | 364 | 211 | 412 | 238 | 460 | 264 | 508 | 291 | 556 |
| 185 | 365 | 212 | 413 | 238 | 461 | 265 | 509 | 292 | 557 |
| 186 | 366 | 212 | 414 | 239 | 462 | 266 | 510 | 292 | 558 |
| 186 | 367 | 213 | 415 | 239 | 463 | 266 | 511 | 293 | 559 |

MANUAL CORRECTIONS AND MODIFICATIONS

While every effort has been made to ensure that the information contained in this manual provided to you is updated, and contains accurate information, if you believe that an error has been made, or simply would like to suggest modifications, or improvements, please fill in the information below and fax it to 570-636-9874 or mail it to the address below. A review of any received forms will be considered on a regular basis.

Name _____

Address _____

City _____ State _____ Zip _____

Page Number in which error exists _____

Description of Error _____

Suggestions or improvements to this manual: _____

Fax to 570-636-9874
- or -
Mail to:
Garland Commercial Industries
McDonalds Sale / Service Account
185 East South Street
Freeland, PA 18224

Thank you for your continued support!
Garland P/N 1881002 REV3IN (060104)

