

GAS

MODEL NUMBERS

MWG-9501
MWGH-9501
MWGF-9501
MWGL-9501
MWGR-9501



GARLAND

OPERATIONS MANUAL

MANUFACTURED EXCLUSIVELY FOR
McDonald's
BY

GARLAND COMMERCIAL INDUSTRIES, INC.
185 EAST SOUTH STREET
FREELAND, PENNSYLVANIA 18224
TOLL FREE: (800) 446-8367
PHONE: (570) 636-1000
FAX: (570) 636-9874

Come visit us on the web at

www.garland-group.com

E-mail: clamshell@garland-group.com



NOTE: This manual pertains to all grill models listed above. The reader/operator must interpret its contents to applicable needs. However, if there is any question of interpretation of any literature pertaining to Garland grills, please contact our Customer Service Department at one of the phone numbers listed above.

**FOR YOUR SAFETY
DO NOT STORE OR USE GASOLINE OR
OTHER FLAMMABLE VAPORS OR LIQUIDS
IN THE VICINITY OF THIS OR ANY OTHER
APPLIANCE**

WARNING:
IMPROPER INSTALLATION, ADJUSTMENT, ALTERATION,
SERVICE OR MAINTENANCE CAN CAUSE PROPERTY
DAMAGE, INJURY OR DEATH. READ THE INSTALLATION,
OPERATING AND MAINTENANCE INSTRUCTIONS
THOROUGHLY BEFORE INSTALLING OR SERVICING
THIS EQUIPMENT.

- KEEP APPLIANCE AREA FREE AND CLEAR OF COMBUSTIBLES!
 - PLEASE READ ALL SECTIONS OF THIS MANUAL AND RETAIN FOR FUTURE REFERENCE
 - THIS PRODUCT HAS BEEN CERTIFIED AS COMMERCIAL COOKING EQUIPMENT AND MUST BE INSTALLED BY PROFESSIONAL PERSONNEL AS SPECIFIED.
 - ALL BURNER ADJUSTMENTS AND SETTINGS MUST BE MADE BY A QUALIFIED GAS TECHNICIAN
- CAUTION: THIS EQUIPMENT MUST ONLY BE OPERATED UNDER AN APPROVED HOOD SYSTEM.

THIS EQUIPMENT MUST BE INSTALLED AND COMMISSIONED BY A PROFESSIONAL FACTORY TRAINED TECHNICIAN.



Rev 3b P/N 1881060 IN(080205)

Table of Contents

Table of Contents

WARRANTY	5
INTRODUCTION	5
SAFETY	5
SHIPPING DAMAGE CLAIM PROCEDURE	6
LIGHTING INSTRUCTIONS	6
SHUT DOWN INSTRUCTIONS	7
CLEANING AND MAINTENANCE	7
SPECIFICATIONS	9
FULL SIZE GAS GRILL MODEL MWG-9501	9
HALF SIZE GAS GRILL MODEL MWG-9501	10
FULL SIZE FLAT GRILL MODEL MWGF-9501	11
HALF & HALF FULL SIZE GAS RIGHT SIDE CLAM ONLY MODEL MWGR-9501	12
HALF & HALF FULL SIZE LEFT SIDE CLAM ONLY MODEL MWGL-9501	13
RELEASE MATERIAL INSTALLATION (OPTIONAL)	14
RELEASE MATERIAL INSTALLATION	16
2-SPEED FAN INTERFACE INFORMATION	17
UNIT INSTALLATION	17
<i>National Code Requirements</i>	18
<i>Gas Connections, and pipe sizing</i>	18
<i>Electrical Instructions</i>	19
<i>Ventilation and Clearance</i>	19
<i>Changing to a different type of gas</i>	19
<i>Burner Air Adjustment</i>	19
<i>Ignitor Adjustment</i>	20
CLAMSHELL GRILL CONTROLS	20
DESCRIPTION OF GRILL CONTROLS	21
<i>General Overview</i>	21
<i>The Master Power (Pushbutton (ON / OFF))</i>	21
<i>Indicator Lights</i>	21
<i>Ignition Status Indicator Light - Center LED</i>	21
<i>Up Arrow Button - Two Functions</i>	21
<i>Right Arrow Button - Two Functions</i>	21
<i>Program Mode Button - Two Functions</i>	21
<i>Menu Button - Two Functions</i>	21
<i>Temperature / Function Button - Two Functions</i>	22
<i>Standby Button - Black</i>	22
NORMAL OPERATING MODES	22
<i>Preheat Mode (Eprom 6.20 and higher)</i>	22
<i>To Cook in Clam Grill Mode:</i>	22
<i>Cancel / Raise Button - Green</i>	22
<i>To Cook in Flat Grill Mode:</i>	22
<i>Standby Mode:</i>	23
<i>EXIT the Standby Mode:</i>	23
<i>Standby Alarm (Version 6.20 and higher)</i>	23
<i>To Display the Current Temperature</i>	23
<i>To View Settings for a Menu Item:</i>	23
<i>To Reset Factory Defaults</i>	23
<i>To Clean the Grill:</i>	24
<i>Breakfast to Lunch Transition (Transition Cooking)</i>	24
<i>Multi-Stage Cooking</i>	24
PROGRAM LOGIC CHART	25
SYSTEM SETUP	26
<i>To Display Temperatures in F or C</i>	26
<i>To Change the Speaker Volume (High / Low)</i>	26
<i>To Change the Gap Calibration</i>	26
<i>To Enable / Disable Start Delay</i>	26
<i>To Change Start Delay Timer</i>	27
<i>To Change the Standby Alert Feature - EPROM Chip Ver. 6.20 and higher</i>	27

TABLE OF CONTENTS

<i>To Enable / Disable Multi-Stage Cooking - EPROM Chip Ver. 7.XX and higher</i>	27
MENU ITEMS	28
<i>To Add or Delete a Menu Item</i>	28
<i>To Change the Remove Time</i>	28
<i>To Change the Remove Time Alarm (Auto/Manual)</i>	28
<i>To Change the Sear Time</i>	29
<i>To Change the Sear Time Alarm (Auto/Manual)</i>	29
<i>To Change the Toast Buns Time</i>	29
<i>To Change the Toast Buns Alarm (Auto/Manul)</i>	29
<i>To Change Turn Time</i>	30
<i>To Change Turn In Alarm (Auto / Manual)</i>	30
<i>To Change the grill surface set temperature</i>	30
<i>To Change the upper platen set temperature</i>	31
<i>To Enable High Limit Test - GRILL SURFACE (Chip V. 3.52 and 4.0* ONLY)</i>	31
<i>To Enable High Limit Test - PLATEN (Chip V. 3.52 and 4.0* ONLY)</i>	31
TO ADD / PROGRAM NEW MENU ITEMS	32
<i>To Add / Program an [Option Menu - CLAM]</i>	32
<i>To Add / Program an [OPTION MENU - FLAT]</i>	33
PROBE CALIBRATION	34
OPTIONAL ACCESSORIES	36
TROUBLESHOOTING	37
POSSIBLE ERROR MESSAGES	37
<i>"Probe Open"</i>	37
<i>"Clam did not go down"</i>	37
<i>"Upper Platen Stuck"</i>	37
<i>"Eprom Corrupt"</i>	37
<i>"Ignition Failure"</i>	37
<i>"High Limit"</i>	37
<i>"Motor Overcurrent"</i>	37
<i>"Faulty Element / Shorted Probe"</i>	37
IN STORE TROUBLESHOOTING GUIDE	38
CONTROLLER MENU ITEMS	40
CONTROLLER MENU ITEMS (EPROM CHIP VER. 7.XX)	42
TEMPERATURE CONVERSION (F / C)	44
MANUAL CORRECTIONS AND MODIFICATIONS	47

WARRANTY

This warranty covers defects in material and workmanship under normal use providing that:

- a) the equipment has not been accidentally or intentionally damaged, altered or misused.
- b) the equipment is properly installed, adjusted, operated and maintained in accordance with national and local codes and in accordance with the installation instructions provided with this product.
- c) the warranty serial number affixed to the appliance by us has not been defaced, obliterated or removed.
- d) an acceptable report for any claim under this warranty is supplied to us.

The equipment warranty coverage remains in force for one (1) year (parts and labor) from the date the equipment is put into operation and two (2) years (parts only) for the microprocessor controller, motor speed controller and upper platen (aluminum casting and shroud).

The Garland Group agrees to repair or replace, at it's option, any part that proves to be defective in material or workmanship at no charge for the part or normal labor.

We assume no responsibility for installation, adjustments, diagnosis, or normal maintenance such as: lubrication of springs or valves. We exclude failures caused by erratic voltage or gas supplies. We assume no responsibility for travel costs beyond 100 miles round trip, travel other than overland, and overtime costs of repair. We exclude broken glass, paint and porcelain finish, surface rust, gasket material, ceramic material, light bulbs and fuses from normal coverage. We exclude damage or dysfunction caused by fire, flood, and like "Acts of God" that are beyond the control of The Garland Group.

The Garland Group's liability on a claim of warranty shall not exceed the price of the material and/or service, which caused the claim. This warranty is limited and is in lieu of all other warranties, expressed or implied. The Garland Group, our employees, or our agents shall not be held liable for any claims of personal injury or consequential damage or loss. This warranty gives you specific legal rights, and you may have other rights which vary from state to state.

INTRODUCTION

The Garland clamshell grill, manufactured exclusively for McDonald's, provides a method for efficient two-sided cooking, while accommodating a variety of products. The unit will also serve as a flat grill, and meets all of McDonald's standards for safety, efficiency, and cleanliness.

SAFETY

Always follow these safety precautions when operating the clamshell grill.

THIS GRILL MUST be operated by persons who have been given adequate training.

CAUTION: THIS EQUIPMENT MUST ONLY BE OPERATED UNDER AN APPROVED HOOD SYSTEM.

DO NOT OPERATE THE GRILL UNLESS IT HAS BEEN COMMISSIONED (START-UP) BY A FACTORY AUTHORIZED SERVICE CENTER.

DO NOT operate the grill without reading this operation manual.

DO NOT operate the clamshell grill unless it has been properly installed and grounded.

DO NOT operate the clamshell grill unless all service and access panels are in place and fastened properly.

The Garland clamshell grill is a semi-automatic cooking appliance. The upper platen is lowered automatically, following the manual; two-handed initiation of the cooking cycle, and the upper platen is raised automatically upon completion of the cooking cycle.

When two sided cooking, the area between the upper platen and the griddle plate should be regarded as a "danger zone". During two sided cooking the operator must not be within this danger zone. When used as a flat grill, then this area is no longer a danger zone, the platens do not move.

For whatever reason, be it cleaning, maintenance, normal operation, any exposed person must use extreme caution if within this danger zone.

In two side cooking the upper platen remains in the lowered position by nature of it's own weight. It is not locked down. It can be raised by lifting of the handle on the front of the platen, which pivots the platen about its rear mounting point.

The clamshell grill may during its operation emit airborne noise equivalent to a continuous A weighted sound pressure level of 73dB(A).

The clamshell grill must only be used for single and two sided cooking of foodstuffs in a McDonald's store and must not be used for any other purpose.

WARNING: To avoid serious personal injury:

DO NOT attempt to repair or replace any part of the clamshell grill unless all main power supplies to the grill have been disconnected.

USE EXTREME CAUTION in setting up, operating and cleaning the clamshell grill to avoid coming in contact with hot grill surfaces or hot grease. Suitable protective clothing should be worn to prevent the risk of burns.

WARNING: This appliance must not be cleaned with a water jet. **DO NOT** apply ice to a **HOT** grill surface.

NOTE: All warning labels and markings on the grill, which call attention to further dangers and necessary precautions.

HAZARD COMMUNICATION STANDARD, (HCS) - The procedures in this manual include the use of chemical products. These chemical products will be printed in bold face, followed by the abbreviation (HCS) in the text portion of the procedure. See the Hazard Communication Standard, (HCS) manual for the appropriate Material Safety Data Sheet(s), (MSDS).

WARNING: After turning the master power switch to the **START** position, the grill will go through an initialization process. If the upper platens are in the lowered position they will return to their raised upper position. This movement takes approximately 8 seconds.

MAINTENANCE - the platen support arms carriage block bearing bushes, the platen adjuster nuts, the platen support (shoulder) bolt and the cam follower should be checked annually for wear. Should there be any noticeable play in the bearing bushes and any visible wear on the platen adjuster nuts, platen support bolts or cam follower, then they must be replaced.

MAINTENANCE - the audible alarm that sounds on platen lowering, platen raising and 5 seconds before the completion of the cooking cycle is to advise the operator that the platen is about to move. The function of this device may be tested by pushing the left hand **CANCEL** button. If no sound is heard, ensure that the alarm volume is not set to low in **SYSTEM SETUP**. If there is still no sound then a service engineer should be called out to rectify the fault.

SERVICE AND CLEANING - The grill is secured in the grill bay by the installer using two anchors that lock onto the front casters. If the grill is to be moved out of the bay for cleaning or service, remove the anchor from each caster by turning the knob counterclockwise to loosen the retainer. When the retainer is free of the caster, lay the assembly aside

on the floor.

NOTE: The anchor assembly remains fastened to the back wall of the grill bay.

After service or cleaning is complete, return the grill to its position in the bay and reattach the anchors by placing the retainer on the caster post and turning the knob clockwise to tighten.

NOTE: For safety reasons, the grill must be secured in the grill bay in this manner before operation can resume.

SHIPPING DAMAGE CLAIM PROCEDURE

Please note that the Garland equipment was carefully inspected and packed by skilled personnel before leaving the factory. The transportation company assumes full responsibility for safe delivery upon acceptance of the equipment.

What to do if the equipment arrives damaged:

1. File a claim immediately regardless of the extent of damage.
2. Be sure to note, "visible loss or damage," on the freight bill or express receipt and have the person making the delivery sign it.
3. Concealed loss or damage: if damage is unnoticed until the equipment is unpacked, notify the freight company immediately, (within 15 days), and file a concealed damage claim.

LIGHTING INSTRUCTIONS

1. Ensure that the flexible gas hose is connected to the grill and the power cords are plugged into the receptacles.
2. Turn the main power switch **ON** and allow the controls to go through the power-up self-check. Once the control(s) panel displays the word "**OFF**", the unit is ready to begin the heating process.
3. By selecting any of the menu items (pressing the menu button) the controls will automatically initiate the heating cycle appropriate for the menu item selected. The burner(s) should light and heat until the temperature specified by the menu item has been obtained.
4. If ignition of the burner does not occur on the first trial, the second from the bottom indicator light will flash amber. If the burner(s) does not light within four trials for ignition, the control(s) will display a flashing warning "**IGNITION FAILURE**", the flashing amber light will turn to solid red and an audible alarm will sound. If this occurs, turn the main power switch off, wait 5 minutes, then repeat steps 2 and 3.

SHUT DOWN INSTRUCTIONS

1. To shut down unit at any time, switch the main power switch to off (non-lit) position.
2. For extended shut down periods, switch main power switch to off position, disconnect unit from gas supply line and unplug electrical connections.

CLEANING AND MAINTENANCE

Tools: McD Hi-Temp Grill Cleaner (HCS), McD All Purpose Super Concentrate (HCS), McD's NO-SCRATCH(Pad and Pad Holder, a suitable container, High-Temperature Pot Brush and Grill Cloth, Stainless Steel Pan Filled With Lukewarm Water, Protective Gloves, (to protect hands from heat), Grill Squeegee and Grill Scraper.

Warning: The upper platen surface and edges are very hot! To prevent burn injuries, use extreme caution when wiping down release sheets and platen edges.

Important: Frequently throughout the day, (at least 4 times per hour), thoroughly wipe down the release sheets and platen edges with a damp grill cloth.

1. PRESS the "MENU" button until "CLEAN MODE" is displayed, (the control will maintain the proper cleaning temperature). Repeat with the other control. "READY TO CLEAN" will be displayed and an audible alarm will sound when the grill is at the proper cleaning temperature. PRESS the "MENU" button to display "OFF." The "OFF" position on the controllers allows the operator to raise and lower the upper platens, (for clamshell grills), to alternate positions for proper cleaning of the platen edges.
2. Empty and replace the grease troughs. Grease troughs should be emptied and replaced consistent with store security policy.
3. Put on the protective gloves and wipe down the exposed surface of the release sheet with a damp grill cloth.
4. Remove the release sheet locking clips and bars. Clean the release sheets following the instructions provided by your local cleaning chemical supplier.
5. Scrape only the lower grill surface with the grill scraper, and squeegee any residue into the grease troughs with the grill squeegee.

Caution: Do not scrape or otherwise scratch the upper platens. The use of metal scrapers, abrasive pads, or wire brushes will permanently damage the surface of the upper platens.

6. Open one packet of McD Hi-Temp Grill Cleaner, (HCS), and empty the contents into a suitable container. (One packet cleans a 3ft. grill).
7. Firmly attach the McD NO-SCRATCH(Pad to the pad holder.
8. Dip the NO-SCRATCH(Pad into the grill cleaner.
9. Spread a light coating of grill cleaner over the entire platen surface, BACK, FRONT AND SIDE EDGES of both upper platens. DO NOT SCRUB WHILE APPLYING THE PRODUCT.
10. After applying the grill cleaner, lightly scrub the platen surfaces, BACK, FRONT AND SIDE EDGES with the NO-SCRATCH(Pad until all the soil has been liquefied by the grill cleaner. For stubborn soils, apply additional grill cleaner and lightly scrub. DO NOT RINSE THE PLATENS AT THIS TIME.
11. Starting at the back of the lower grill, spread a light coating of grill cleaner over the entire surface. DO NOT SCRUB WHILE APPLYING THE PRODUCT.
12. After applying the grill cleaner, lightly scrub the grill surface with the NO-SCRATCH(Pad until all the soil has been liquefied
13. For Clamshell Grills, rinse the upper platens with a dripping wet grill cloth. RINSE PLATEN EDGE THOROUGHLY, THEN WIPE DOWN BACK EDGE OF PLATEN.
14. Carefully pour small quantities of lukewarm water onto the grill while brushing the surface, backsplash, and bullnose with a LONGLIFE(pot brush or equivalent high-temperature brush. Continue until the water no longer boils away and the grill remains wet. Squeegee dry.

Caution: Ice, cold water, or large quantities of water must never be applied to the grill plate or upper platen. Severe damage to the grill will occur!

15. Clean the release sheets as follows:
16. Place the sheets on the lower grill. Scrub both sides of the sheets with the same McD NO-SCRATCH(Pad used on the grill.

Note: It is generally not necessary to apply additional product to the NO-SCRATCH(Pad. If the pad is not wet enough, rewet with a small amount of water, if no cleaner is left.

- a. Rinse both sides of the sheets with a wet grill cloth.
- b. Rinse the lower grill by flooding the surface twice with lukewarm water. Squeegee after each rinse.

17. Wipe the lower grill surface, backsplash, bullnose, and hood with a clean, damp grill cloth.

AFTER CLEANING - Apply a thin coat of fresh shortening to the lower grill surface only. Wipe down the surrounding areas. Empty, wash, rinse, and replace the grease troughs.

Note: Repeat this procedure to clean additional grills. Reverse NO-SCRATCH(Pad, and use clean side.

CLEANING AFTER EACH RUN OF PRODUCT:

Using grill scraper, scrape grease on lower grill plate from front to back only. Do not scrape across the rear of the lower grill plate with grill scraper. Use wiper squeegee to clean release material sheet on upper platen in a downward motion. Hold handle at a slight upward angle with wiper end facing downward. Do not press hard against the release material sheet to prevent scratching or tearing.

Push the grease at the rear of the lower grill plate into the grease cans using the wiper squeegee only. Do not use the grill scraper for this step.

Warning: Grill Temperatures will cause severe skin burns.

Use the grill cloth to clean back splash and bullnose areas as needed during operation.

Note: To increase life of release material sheet, wipe down with folded grill cloth four (4) times every hour.

SPECIFICATIONS

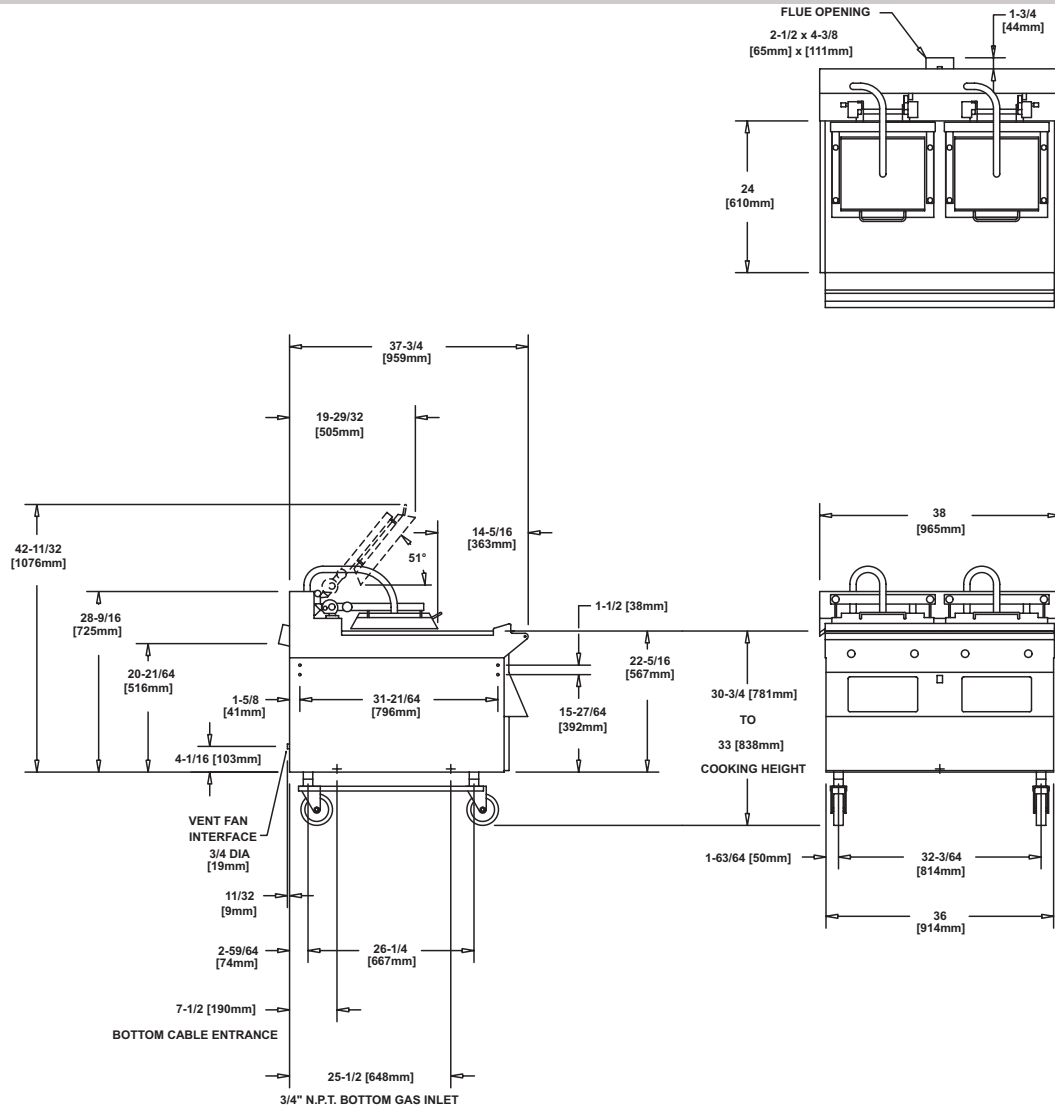

FULL SIZE GAS GRILL MODEL MWG-9501

Gas Input Specifications

BTU / HR	KW / R.	Gas Inlet Size
70,000	20.5	3/4" NPT

ELECTRICAL REQUIREMENTS	KW LOAD (TOTAL)	NOMINAL AMPERES PER LINE, (THREE PHASE ONLY)									NEMA RECEPTACLE REQUIRED
		208 VOLT			220 VOLT			240 VOLT			
ONE (1) 30 - AMP CIRCUIT	11.2 KW	X	Y	Z	X	Y	Z	X	Y	Z	ONE (1) #15-30R
		31	31	31	29.5	29.5	29.5	27	27	27	
ADDITIONAL REQUIRED CONNECTION	HVAC HOOD / FIRE SUPPRESSION INTERLOCK CIRCUIT - 120V, 7 AMP, SINGLE PHASE										L21-21R

SPECIFICATIONS

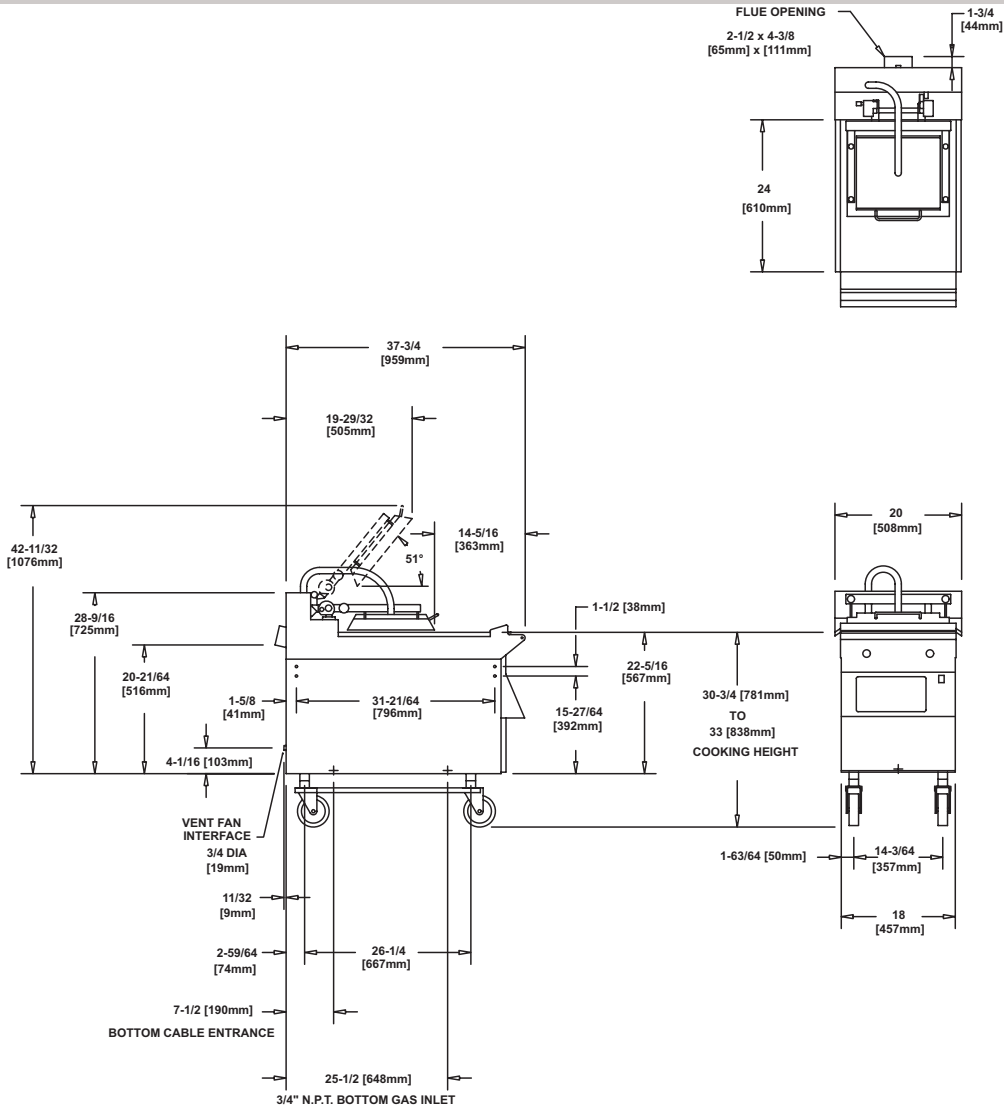

HALF SIZE GAS GRILL MODEL MWG-9501

Gas Input Specifications		
BTU / HR	KW / R.	Gas Inlet Size
35,000	10.3	3/4" NPT

ELECTRICAL REQUIREMENTS	KW LOAD (TOTAL)	NOMINAL AMPERES PER LINE, (THREE PHASE ONLY)									NEMA RECEPTACLE REQUIRED
		208 VOLT			220 VOLT			240 VOLT			
		X	Y	Z	X	Y	Z	X	Y	Z	
ONE (1) 30 - AMP CIRCUIT	5.6 KW	15.5	15.5	15.5	14.8	14.8	14.8	13.5	13.5	13.5	ONE (1) #15-30R
ADDITIONAL REQUIRED CONNECTION	HVAC HOOD / FIRE SUPPRESSION INTERLOCK CIRCUIT - 120V, 7 AMP, SINGLE PHASE									L21-21R	

SPECIFICATIONS

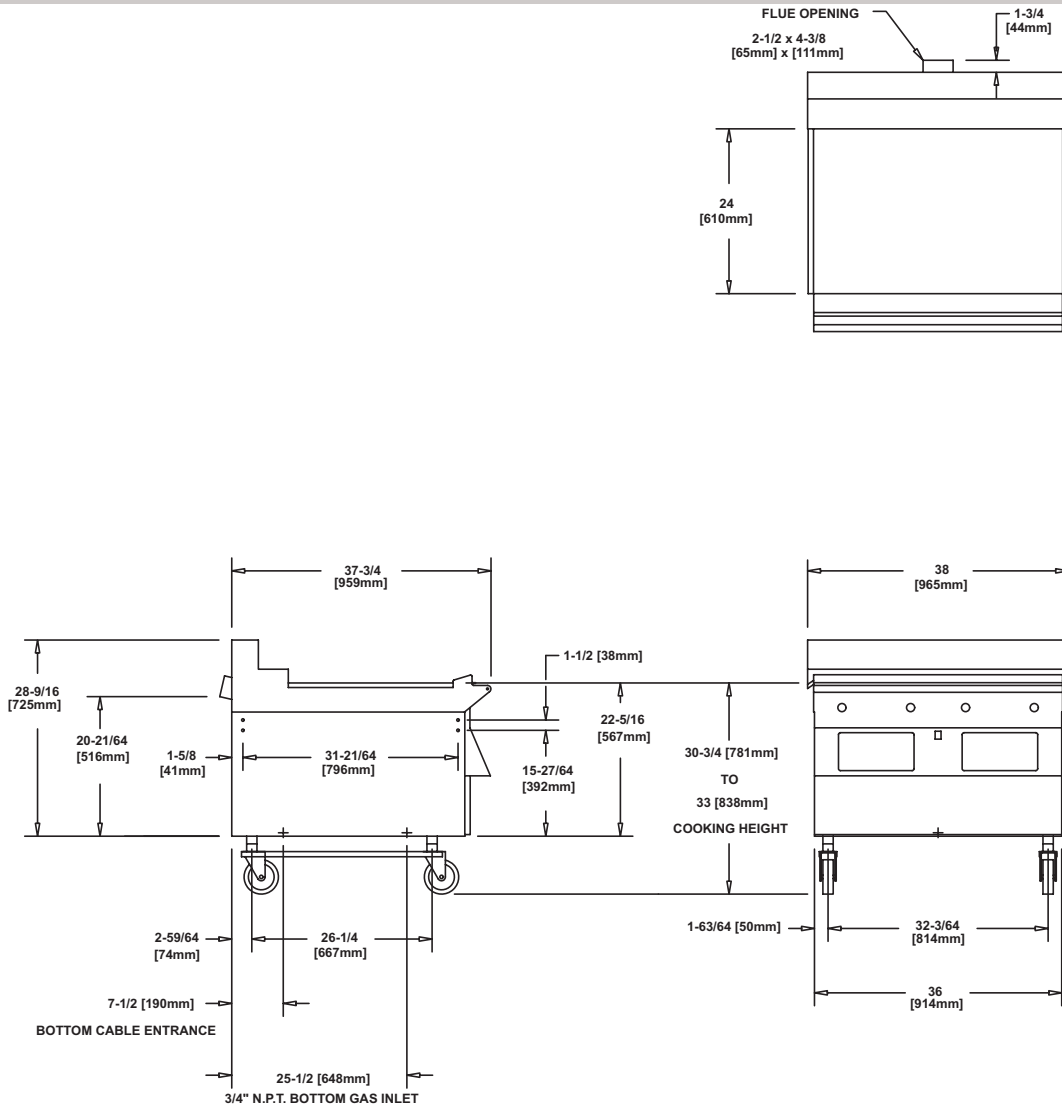

FULL SIZE FLAT GRILL MODEL MWGF-9501

Gas Input Specifications		
BTU / HR	KW / R.	Gas Inlet Size
70,000	20.5	3/4" NPT

ELECTRICAL REQUIREMENTS	KW LOAD (TOTAL)	NOMINAL AMPERES PER LINE, (THREE PHASE ONLY)									NEMA RECEPTACLE REQUIRED
		208 VOLT			220 VOLT			240 VOLT			
		X	Y	Z	X	Y	Z	X	Y	Z	
ONE (1) 30 AMP CIRCUIT	5.0 KW	13.8	13.8	13.8	13	13	13	12	12	12	ONE (1) #15-30R
ADDITIONAL REQUIRED CONNECTION	HVAC HOOD / FIRE SUPPRESSION INTERLOCK CIRCUIT - 120V, 7 AMP, SINGLE PHASE									L21-21R	

SPECIFICATIONS

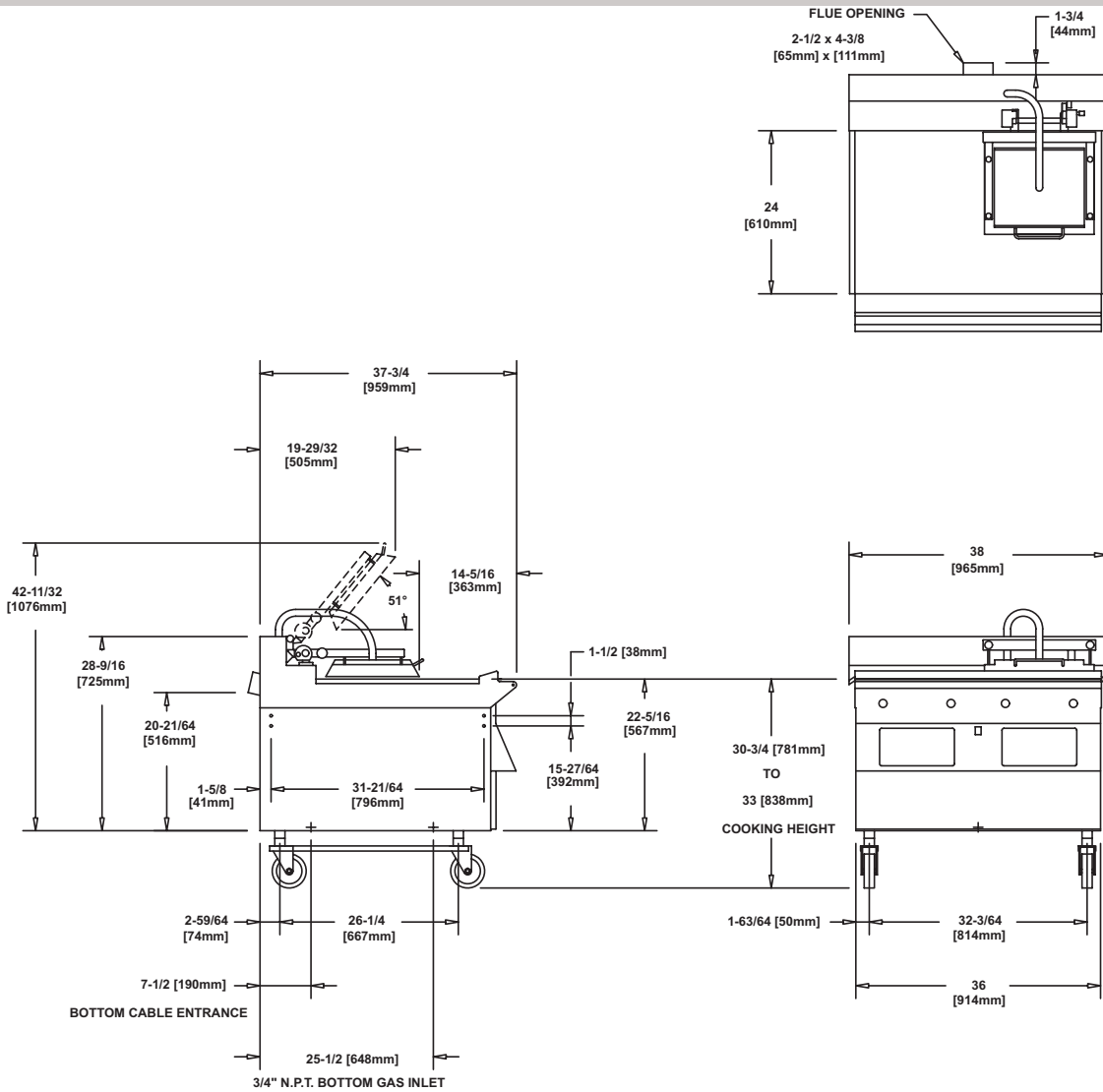

HALF & HALF FULL SIZE GAS RIGHT SIDE CLAM ONLY MODEL MWGR-9501

Gas Input Specifications		
BTU / HR	KW / R.	Gas Inlet Size
70,000	20.5	3/4" NPT

ELECTRICAL REQUIREMENTS	KW LOAD (TOTAL)	NOMINAL AMPERES PER LINE, (THREE PHASE ONLY)									NEMA RECEPTACLE REQUIRED
		208 VOLT			220 VOLT			240 VOLT			
		X	Y	Z	X	Y	Z	X	Y	Z	
ONE (1) 30 - AMP CIRCUIT	8.1 KW	22.5	22.5	22.5	21.3	21.3	21.3	19.5	19.5	19.5	ONE (1) #15-30R
ADDITIONAL REQUIRED CONNECTION	HVAC HOOD / FIRE SUPPRESSION INTERLOCK CIRCUIT - 120V, 7 AMP, SINGLE PHASE									L21-21R	

SPECIFICATIONS

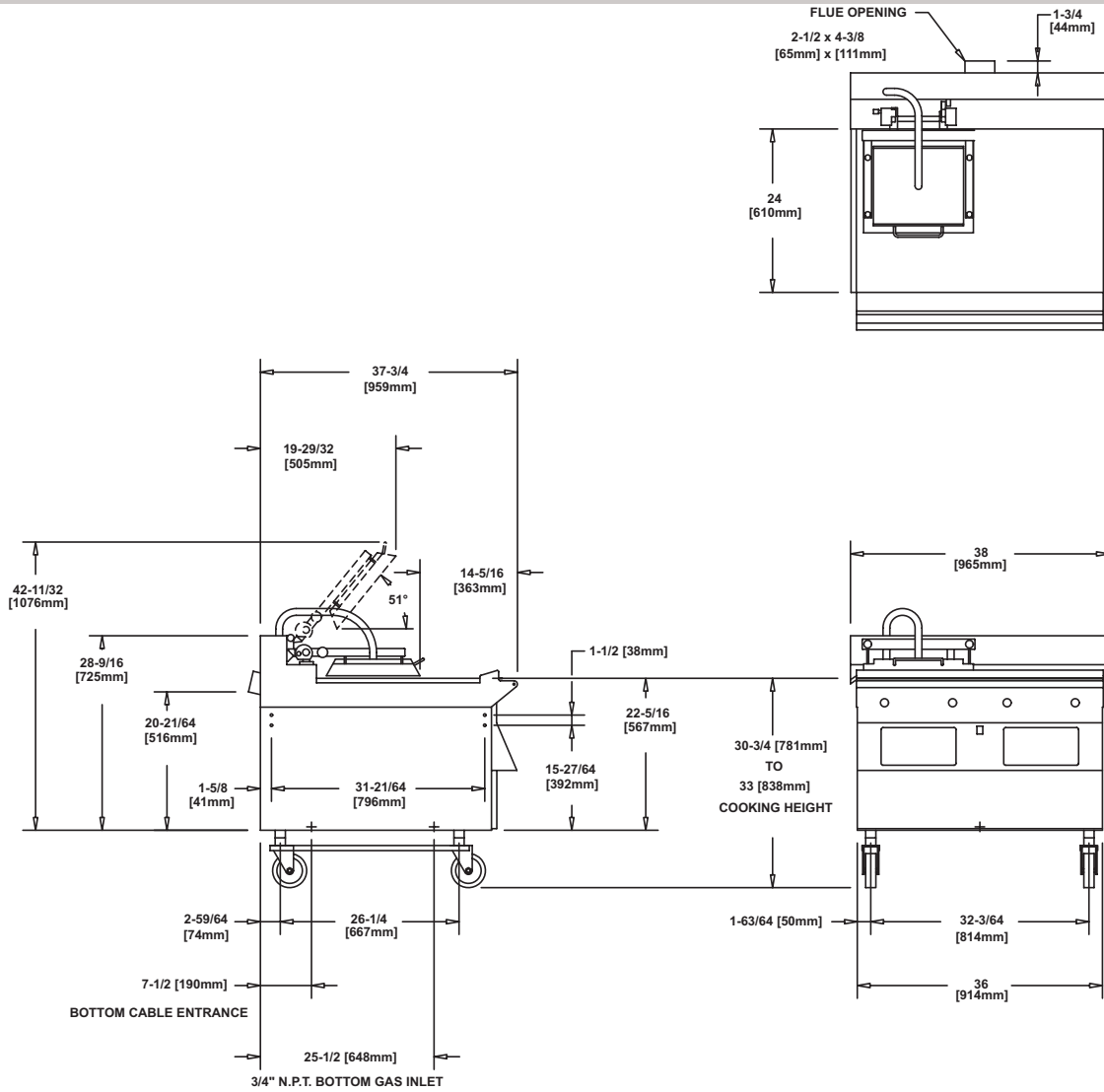

HALF & HALF FULL SIZE LEFT SIDE CLAM ONLY MODEL MWGL-9501

Gas Input Specifications		
BTU / HR	KW / R.	Gas Inlet Size
70,000	20.5	3/4" NPT

ELECTRICAL REQUIREMENTS	KW LOAD (TOTAL)	NOMINAL AMPERES PER LINE, (THREE PHASE ONLY)									NEMA RECEPTACLE REQUIRED
		208 VOLT			220 VOLT			240 VOLT			
		X	Y	Z	X	Y	Z	X	Y	Z	
ONE (1) 30 - AMP CIRCUIT	8.1	22.5	22.5	22.5	21.3	21.3	21.3	19.5	19.5	19.5	ONE (1) #15-30R
ADDITIONAL REQUIRED CONNECTION	HVAC HOOD / FIRE SUPPRESSION INTERLOCK CIRCUIT - 120V, 7 AMP, SINGLE PHASE									L21-21R	

RELEASE MATERIAL INSTALLATION (OPTIONAL)

NOTE: TEFLON ROLLUP BAR ASSEMBLY'S ARE SEPARATE FOR LEFT AND FOR RIGHT. NOTE THE "L" OR "R" STAMPED ON THE BRACKET ASSEMBLY FOR CORRECT POSITIONING.

WARNING: UPPER PLATEN TEMPERATURES ARE VERY HOT. PLATEN SHOULD BE COOL WHILE INSTALLING

1. If attached, remove Teflon sheet clips located on the front of the platen.
2. Insure Teflon bar that is bolted to the upper platen is free and clear of carbon buildup, and clean as necessary.
3. Install Teflon rollup bar bracket by placing new rollup over existing Teflon bar, with the set screws facing DOWN (See Figure 1).
4. Tighten set screws using 1/8" allen wrench.

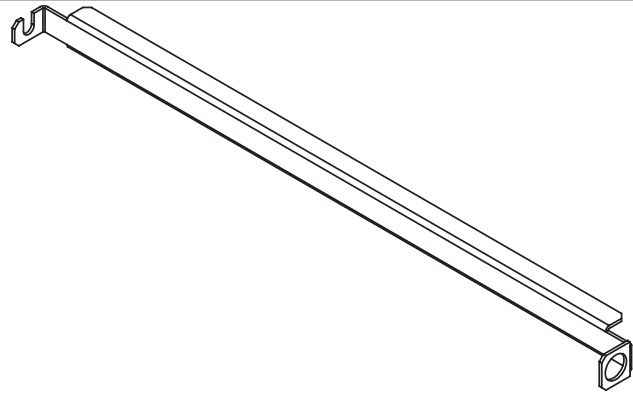

Figure 1 - Teflon Rollup bar bracket

5. Install teflon roller bar in rollup bracket. (See Figure 2)

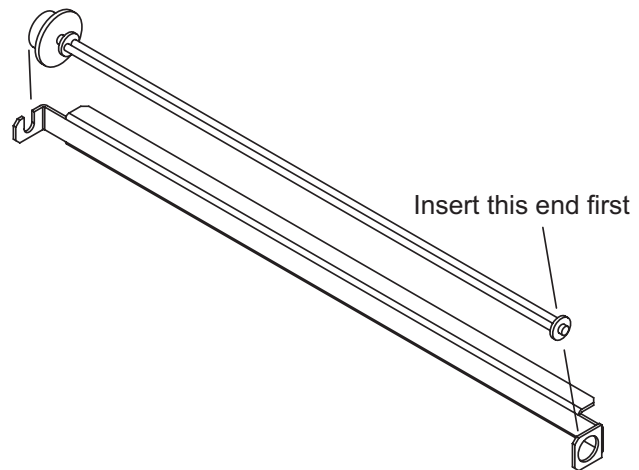
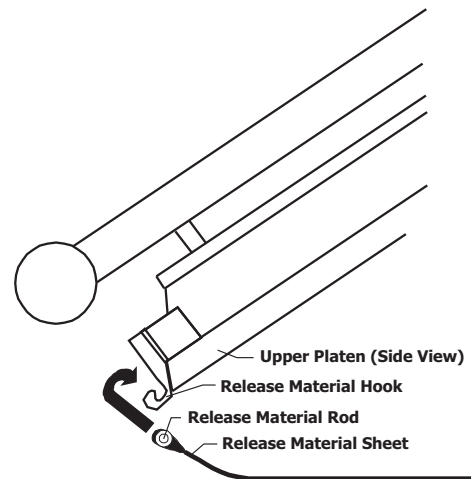
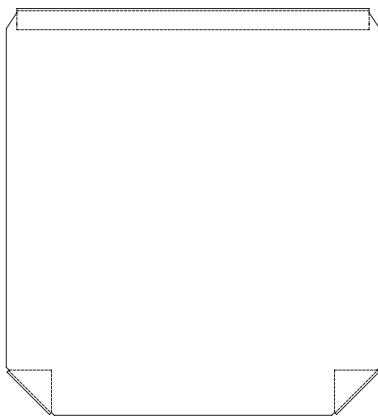
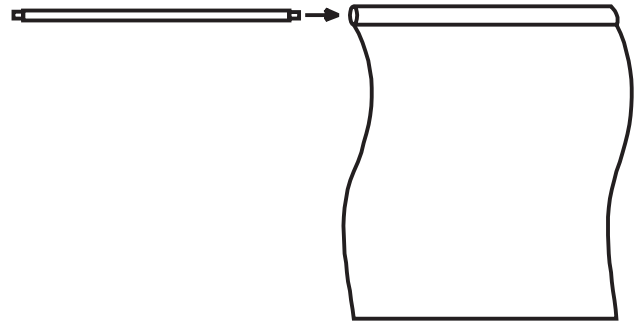

Figure 2 - Inserting teflon roller bar into bracket

RELEASE MATERIAL INSTALLATION (OPTIONAL)

6. Install existing rod through opening on teflon sheet as previously done with existing rod and sheet.
7. Clip existing teflon bar in rear of platen as previously done with existing rod and sheet.
8. Fold corner edges of front of teflon sheet approximately 1 inch on top and side, and insert folded sheet through opening in Teflon rollup.



9. Once inserted, pull through and hold Teflon sheet in center, and turn the tightening knob clockwise (for right platen) and counter-clockwise (for left platen).
10. Once tight, turn locking knob in opposite direction of tightening knob.

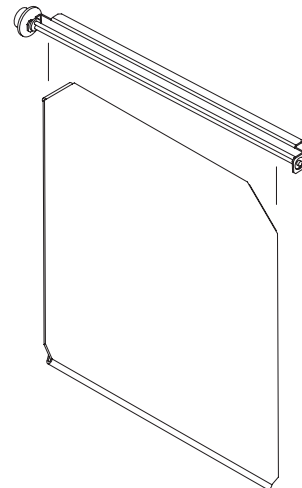

RELEASE MATERIAL INSTALLATION

The following procedures are the procedures for installing the teflon sheets on to the upper platen on the Garland Clamshell grill. The components shown below are included with your grill when purchased.

1. Slide release material rod through hemmed end of the release material sheet.

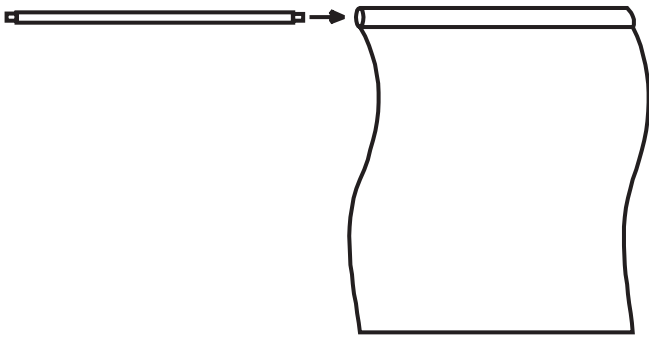

2. Hook release material rod on brackets located at the rear of the upper platen

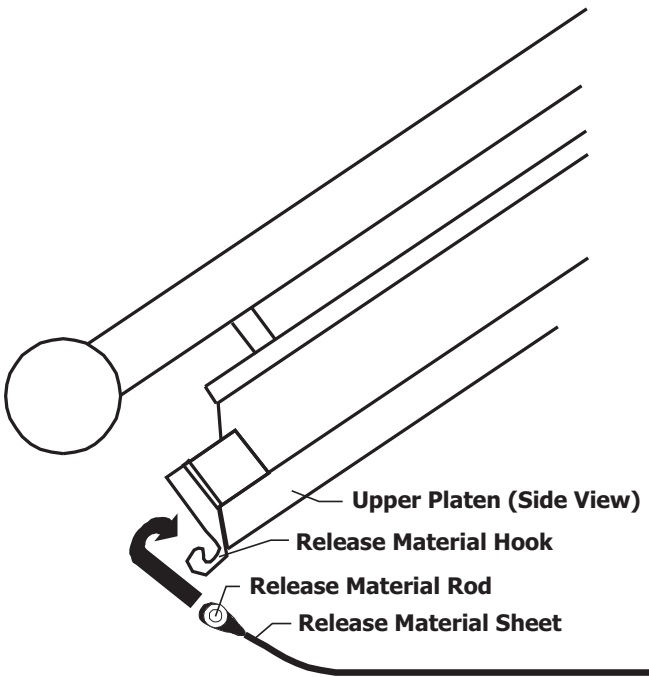

3. Holding the bottom of the release material sheet in place, gently pull the sheet toward the front of the platen.

NOTE: Make sure release material fits smoothly over upper platen.

4. Place locking clips over release material sheet and press into place over release material bar

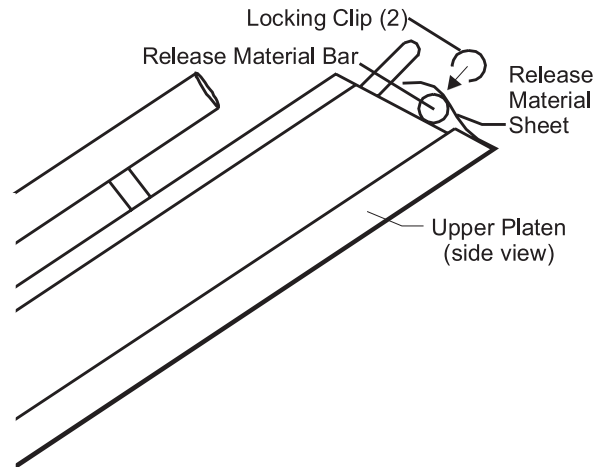

5. Check alignment and tightness of release material against upper platen.

NOTE: Installing release material sheets too tight may cause premature failure of the sheet.

Installing only 1 clip on over the release material bar may cause the release material sheet to be too loose. Ensure that 2 clips are installed on the teflon bar at all times.

Release material sheets should be replaced when:

- Product sticks to release material
- Carbon build-up causes problems in taste or appearance.
- A tear in the release material sheet's cooking area.
- Release material coating is worn off sheet.

NOTE: Rotate the release sheets on daily basis

2-SPEED FAN INTERFACE INFORMATION

This unit is equipped with a 2-speed fan interface (Grills manufactured post grill serial number 0010CL0036). McDonalds stores built post May 2000 are equipped with the capability of a 2-speed interface. In the event that a store is a capable 2-speed fan store, and the grill is not a 2-speed fan unit, a separate 2-speed installation kit is available upon request at a set billable price to the store.

Units equipped with a 2-speed fan interface still require the 5-wire interlock cord, in addition to a separate 3-wire extension cord supplied from the hood exhaust system. 2-speed installation instructions are available upon request.

2-speed activation will occur at the following times:

LOW SPEED (all active AFTER (1) ONE MINUTE)

1. All platens (equipped and are active 2-speed fan grills) go into the standby mode. (For standby mode see page 23).
2. All platens (equipped and are active 2-speed fan grills) are in the OFF mode.
3. All platens (equipped and are active 2-speed fan grills) are idle (in the up position).
4. When grill is initially turned on for initial heat up in the morning.

HIGH SPEED (Active immediately)

1. A cook cycle on at least 1 platen (equipped and are active 2-speed fan grills) is initiated.
2. When grill is initialized using the main ON/OFF Master Power switch for 1 minute.
3. CLEAN MODE.

UNIT INSTALLATION

IMPORTANT: RATING PLATE FOR THIS EQUIPMENT IS LOCATED IN TWO PLACES. ONE IS LOCATED INSIDE BACK PANEL ON LEFT SIDE, SECOND RATING PLATE LOCATED UNDER FRONT CONTROL PANEL ON CENTER.

This equipment must be installed by a competent factory trained, certified, licensed and / or authorized service or installation person.

WARNING. This appliance must be earthed.

Prior to installation, the four castors and two locking channels, supplied loose with the grill, must be securely located on the underside of the base. The castors fitted with a brake must be located at the front of the grill. The castors are located through the locking channel with the folded

edges facing down, such that when all castors are located, they cannot rotate.

This appliance should be connected to a potential equalization system. To facilitate this a labeled equipotential bonding point is fitted to the rear of the grill.

It is recommended that this grill is connected to a residual current (earth leakage) device with a tripping current not exceeding 30mA. The leakage current of this grill will not exceed 5mA.

This grill is supplied with a seven pin socket, as specified by the McDonald's Corporation, for installation in new grill stations. This socket is supplied fitted to the grill at the factory. This socket allows for disconnection from the supply with all pole separation of at least 3mm.

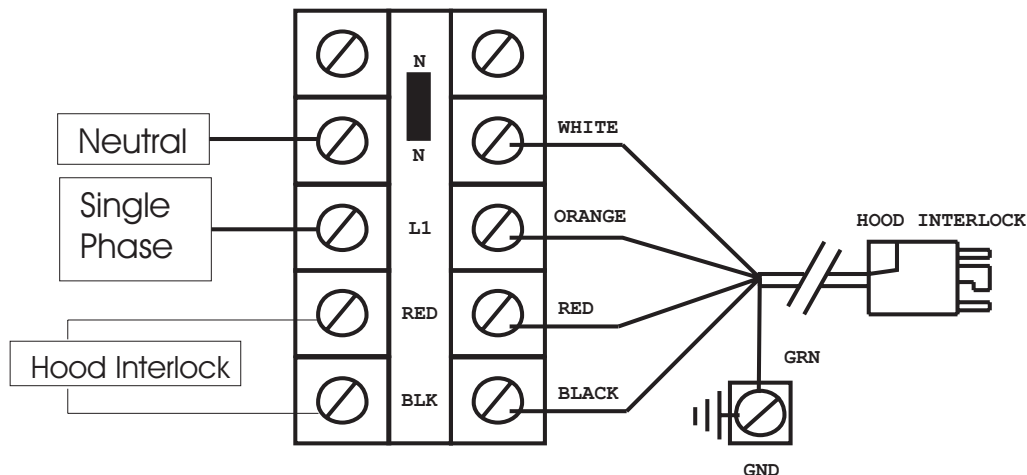

UNIT INSTALLATION

For connection to existing older grill stations, please refer to your Kitchen Equipment Supplier for a conversion kit that allows connection to two power supply cords and one interlock cord. This kit must be connected according to the instructions and wiring diagram supplied with it and the warning labels supplied with the kit must be applied to the grill.

CAUTION: Prior to installation, check the electrical supply to ensure input voltage and phase match the equipment voltage rating and phase. See data plate located rear left side of grill and lower front panel.

Grill is to be located directly under ventilation system and fit securely with grill locks attached.

Once installed in the grill station underneath the ventilation system, the raised position of the upper platen must be adjusted to allow at least 40mm (1.6") of clearance between the handle on the front of the upper platen and the lower lip of the ventilation system hood. The raised position of each platen is adjusted by raising or lowering the upper of the two microswitches (limit switches) in the rear of the grill. The lower microswitch position must not be adjusted.

Grill plate must be level front to back, side to side and diagonally. This leveling must be done with the unit under the hood and in its normal operational position to prevent warping of the grill plate.

NOTE: Once the platen elevation is adjusted, set the mechanical over-run bolts in the rear of the unit to prevent accidental over-run in the event of failure of the upper microswitch.

Installation shall be made with the gas connector that has been specified by The McDonald's Corporation and is supplied loose with the grill. The quick disconnect fitting and gas shut off valve must be installed in the direction indicated on their outer body.

National Code Requirements

The type of gas for which the grill is equipped is stamped on the data plate on the inside rear of the unit and on the lower front panel. Connect a grill stamped for Natural Gas (High (H) or Low (L) Calorific Value) only to Natural Gas; connect those stamped for Propane Gas only to Propane Gas. When installing gas grills, the installation must comply with the latest edition of the National Gas Installation Requirements.

When installing any type of gas-fired commercial kitchen equipment, the requirements of the National Fire Protection Association must be followed implicitly.

Gas Connections, and pipe sizing

The size of the gas line is very important. If the line is too small, the gas pressure at the burner manifold will be low. This will cause slow recovery and delayed ignition. The incoming gas pressure line should be a minimum of 1-1/2". All grills require a 3/4" connection.

Before connecting new pipe the pipe must be blown out to dispose of any foreign particles. These particles will cause improper operation.

When using thread compound, use small amounts on male threads only. Use a compound that is not effected by the chemical action of LP gases. Avoid applying compound to the first two threads to prevent clogging of the burner orifices and control valve.

Have the installer check all gas plumbing with a soap solution for leaks. **DO NOT USE** matches, candles or other ignition sources in checking for leaks. The grill must be disconnected from the gas supply system when pressure testing of that system at pressures in excess of 150mbar.

Check the data plate to determine the proper type of gas before connecting the quick disconnect or piping from the building gas supply.

An incoming gas pressure test nipple is provided on the incoming gas manifold for pressure checks.

Minimum incoming gas pressure for Natural Gas is 15 mbar.
Maximum incoming gas pressure for Natural Gas is 34.5 mbar.

Minimum incoming gas pressure for LP Gas is 27.5 mbar.
Maximum incoming gas pressure for LP Gas is 34.5 mbar

Burner operating gas pressure can be checked at the outlet side of the gas valve at the pressure test point.

Burner manifold pressure for Natural Gas must be 8.75 mbar.
Burner pressure for LP Gas must be 25 mbar.

To adjust the burner pressure, remove the sealing screw from the pressure test nipple, connect a manometer, remove the sealing cap on the gas valve regulator, turn on the grill, adjust the screw in the regulator to give the correct pressure, turn off the grill, refit the regulator sealing cap, remove the

UNIT INSTALLATION

manometer, replace the seal screw in the test nipple and test for gas leaks.

Gas pressures should be checked by the local Gas Company or an authorized service agency only.

Test all piping and connections for gas leaks. A rich soap solution should be used for this purpose. Never use a flame.

Electrical Instructions

All electrically operated appliances must be electrically earthed in accordance with local codes; or in the absence of local codes, with the latest edition of National Wiring Regulations. A wiring diagram is located on the rear panel of the grill. See rating plate in rear of grill, or lower front panel for proper voltages.

WARNING: Installer Note - The grill is designed for connection to a special interlock system. Check receptacle wiring diagram before connecting. Diagram located in this manual and on the rear of the grill.

Ventilation and Clearance

One of the most important considerations of efficient grill operation is proper ventilation and air supply. Insure the grill is installed so the products of combustion are removed efficiently and the ventilation system does not produce drafts that interfere with proper burner operation.

Proper operation of exhaust fans (proper speed, rotation and adjustment) is essential. In addition to the exhaust system the make-up air system (HVAC) for the kitchen is the air supply for the combustion air for the burners. Proper incoming air is essential for all gas operated equipment. Poor incoming make-up will cause inefficient burner operation, delayed ignition and possible burner failure. Insure air balancing is performed on the system as required by the PMS card.

Any ventilation system will break down if improperly maintained. The duct system, the hood, and the filters must be cleaned on a regular basis and kept grease free.

The room containing the grill is required to have a permanent air vent. The minimum effective area of the vent shall be 4.5 cm² per kW. Air vents shall be of such a size to compensate for the effects of any extract fan in the premises.

Changing to a different type of gas

Changing from one gas category to another must only be done by a Qualified Gas Engineer.

To change from category II to III or vice versa, the gas valve, enrichment tube igniter and orifice must be changed to that supplied by the Authorized Service Agency for the gas you are changing to. On completion of changing these three components, you should test all joints for leaks, verify that the manifold pressure is adjusted to the value given in the specification pages in this manual, and repeat the burner air adjustment procedure. This is to be found on the following page in this manual. When the burner is correctly adjusted, the alternate rating plate decal must be placed over the existing rating plates to reflect the new category for which the grill is set.

To change from one gas type to another within the same category (High to Low Calorific Value Natural Gas or vice versa), change the orifice to that supplied by the Authorized Service Agency.

Burner Air Adjustment

1. Visually inspect the color of the burner tile. After the burner has been running for several minutes, the tile surface should be glowing DULL ORANGE, with very little or no blue haze visible above the tile surface. (Note: Just after the burner ignites, it will have some blue haze above the tile surface. This will remain until the tile has heated up and is glowing dull orange). If the burner does not become dull orange, then the burner air supply needs to be adjusted.
2. Loosen the lock nut holding the air adjustment in place. Slowly turn the air adjustment out (counterclockwise). The burner tile surface should begin to brighten.
3. If it brightens, then continue turning the screw counterclockwise until the burn tile surface brightens and then begins to have a blue haze to it again. Stop turning the adjuster. Begin turning the adjuster in while COUNTING THE NUMBER OF TURNS until the tile again has a blue haze. Stop tuning. Divide the number of turns turned in by half and unscrew (counterclockwise) the adjuster that number of turns. The adjustment is now complete. Tighten down the lock nut.

- If the burner flame becomes more blue and starts lifting off the tile, turn the adjuster screw in (clockwise) until the burner tile surface brighten and then begins to have a blue haze to it again. Stop turning the adjuster. Begin turning the adjuster out while COUNTING THE NUMBER OF TURNS until the tile again has a blue haze. Stop tuning. Divide the number of turns turned in by half and screw (clockwise) the adjuster in to that number of turns. The adjustment is now complete. Tighten down the lock nut.

Ignitor Adjustment

The Igniter location is factory set and does not normally require adjustment. Adjustment should only be conducted if the Micro-Amp (μA) reading taken by placing a Micro-Amp (μA) meter in line between the ignition module and the flame sense wire reads below 0.22 Microamps (μA). The normal reading is around 0.80 (μA) to 1.5 (μA). If the reading is low, the igniter can be a moved up or down to achieve the

proper signal. The following is a description of the process.

- Loosen the two 5/16" hex head #10 screws just outboard of the igniter. This allows the igniter and its bracket vertical movement.
- With the Microamp meter in the flame sense line, and the adjustment screws just loose enough to be able to move the igniter assembly up and down, ignite the burner and move the igniter up and down until the maximum Microamp reading is achieved.
- Tighten up the adjuster screws and the job is complete.
- If 0.22 μA cannot be achieved, there may be a defect in the igniter (cracked ceramic).

CLAMSHELL GRILL CONTROLS

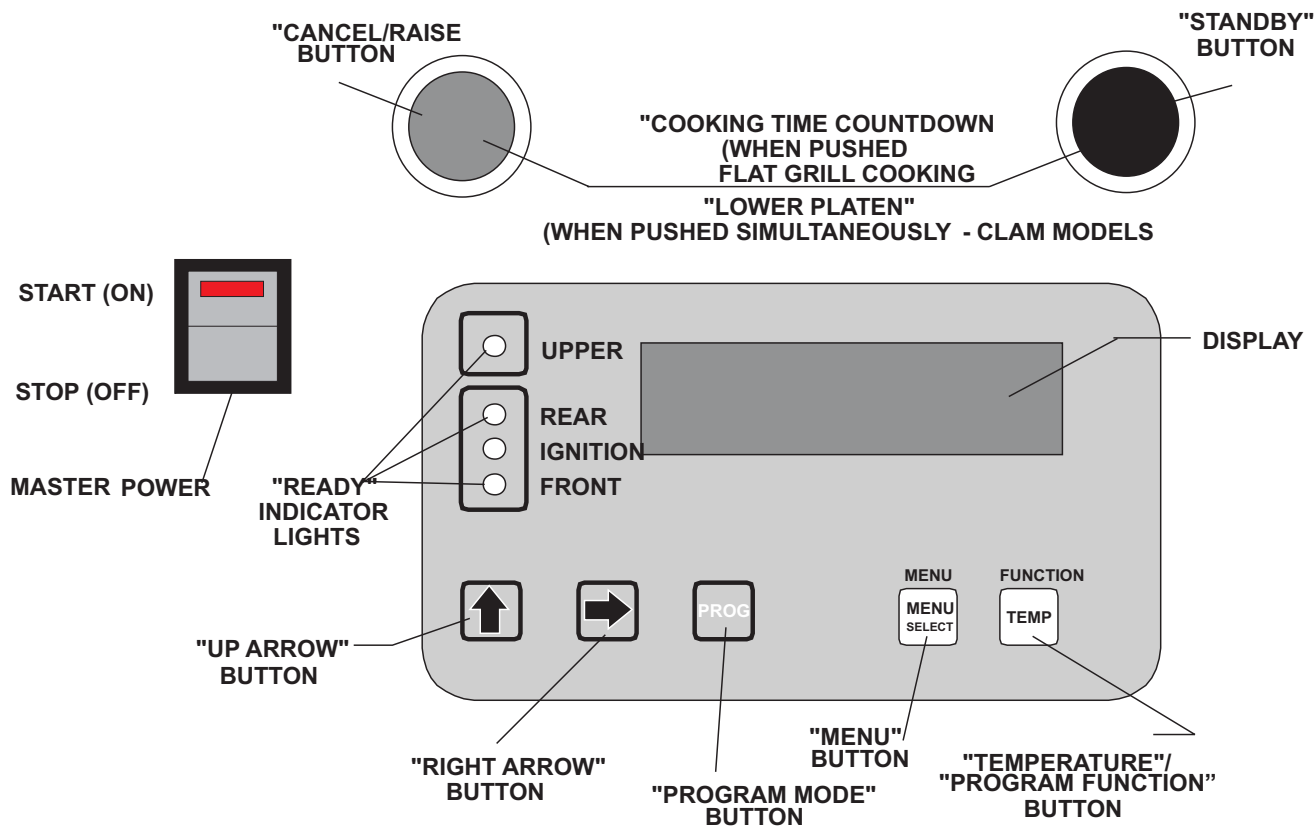

DESCRIPTION OF GRILL CONTROLS

General Overview

The grill control will allow for 2 functions, both described in the following sections.

The “**Normal Operating Mode**”, also known as the Cook Mode is the mode in which is used during normal cooking. In the normal operating mode, the operator can start a cook cycle, cancel a cook cycle, view actual temperatures, view settings for the currently selected menu item, scroll to another menu item (Both forward and backward), and enter the “**Programming Mode**”.

The “**Programming Mode**” is the mode in which the grill operator, manager, or service technician can change various programmed features to specific menu items, or change features that would apply to the entire grill.

The Master Power (Pushbutton (ON / OFF))

Controls power to the grill and must be turned "ON" to start the operation. The controller displays will be active when the switch is "ON".

Indicator Lights

There are four, (4), indicator lights, indicating the temperature status of each zone on the grill, one, (1), on the upper platen, (top light), and three, (3), on the lower, (lower section of lights, top to bottom; rear, center, front, respectively - see diagram on previous page). Each light can display three, (3), different colors, indicating temperature status for the corresponding zone.

Red: The zone(s) is too hot (more than 79°F/27°C over the set temperature) or heat zone(s) failure.

Amber: The zone(s) is calling for heat.

Green: The zone(s) is at or above the set temperature (maximum of 79°F/27°C).

Display:

The controller display will contain information relevant to each operation in both cook and program modes.

Ignition Status Indicator Light - Center LED

The center light in the lower section indicates burner ignition status in the following ways:

Green: status OK.

Amber: Flashing indicates that ignition retrieval has occurred at least once, (4 tries maximum). Once activated the flashing amber light will continue to flash, until ignition

is achieved, (in four tries or less, total), at which time the light will remain amber, but stop flashing.

Red: Indicates that ignition was not accomplished after 4 tries, and that the ignition system has been shut down, requiring a manual reset, (power-down).

Up Arrow Button - Two Functions

- 1) In the cook mode, when depressed, it will display the Remove time, Top Temperature, Bottom temperature and Gap setting for the menu item displayed. Each item will be displayed in the order as stated above. After 5 seconds the display will return to the product menu item.
- 2) In the program mode, it will change the value of the current cursor digit, (see "RIGHT ARROW" button).

Right Arrow Button - Two Functions

- 1) In the program mode various displayed parameters will be shown in numerical values. Each number, when displayed, will have a flashing digit...the cursor digit. The "RIGHT ARROW" button will move the cursor to the next digit. Using the "RIGHT ARROW" button in conjunction with the "UP ARROW" button described above, any parameter value displayed in the program mode may be altered.
- 2) In the cook mode it will scroll backward through the menu items.

Program Mode Button - Two Functions

- 1) The primary function is to access Programming and Calibration of the grill. Push and hold for five (5) seconds. Display will show type and version number. There are two programming features, "MENU ITEMS" and "SYSTEM SETUP".
- 2) The second function is when used with "TEMP" button. To display all temperature zones at the same time, press the "TEMP" button one time and the "PROG" button five (5) times. This will display all four (4) temperature zones.

Menu Button - Two Functions

- 1) In the cook mode this button will allow you to change menu items.
- 2) In the programming mode, the button is used to advance to the next program item.

DESCRIPTION OF GRILL CONTROLS

Temperature / Function Button - Two Functions

- 1) In the Cook mode, each time the button is pressed the current temperature for one zone will be displayed. The displayed temperature begins at the upper platen and works sequentially to the front each time you press the button. After five (5) seconds the display will return to the menu item selected.
- 2) In the Program mode, this button becomes the Function button allowing you to scroll through the functions in the "MENU ITEMS" section of programming.

Standby Button - Black

When both "STANDBY" and "CANCEL/RAISE" buttons are pressed simultaneously, the upper platen will lower to the griddle surface. Press the "STANDBY" button again within five (5) seconds from the start of the cook cycle, to place

the controller in its "standby" state. The display will flash "STANDBY" along with the menu item currently selected. For energy conservation and periods of non-use this will maintain grill temperatures.

Cancel / Raise Button - Green

From the "STANDBY" mode, pushing this button will cancel "Standby" and raise platen. During the cooking cycle, pressing this button will cancel the cooking timer and return the grill to the "IDLE" mode.

NOTE: If the platen is in motion, pressing the "CANCEL/RAISE" button will stop the platen in motion and return the platen to the "IDLE" mode (Eprom version 3.52 and greater).

NORMAL OPERATING MODES

NOTE - TO STOP THE GRILL AT ANY TIME, TURN THE MASTER POWER SWITCH OFF

Preheat Mode (Eprom 6.20 and higher)

The first menu item selected after pressing the "MENU SELECT" button is "PREHEAT". Preheat mode is not actually a menu item, as it does not have a remove time.

Preheat mode has been designed to alarm the operator when the grill is "READY TO COOK".

The upper platen set temperature is 425° F (218°C) and a lower grill surface set temperature of 350°F (177°C). When the grill reaches these set temperatures, the operator can then select a menu item with equal set temperatures, and the grill will be ready to cook.

To Cook in Clam Grill Mode:

1. SELECT a clam grill menu by pressing the "MENU SELECT" button, until you attain the required Clam menu item. The display may read either "TOO COOL" or "TOO HOT," (alternating with the "MENU ITEM"), until the grill attains the set temperature range for that menu, then the "MENU ITEM," (only), will be displayed.

NOTE: If the display reads either "TOO COOL" or "TOO HOT" the upper platen will not lower and initiate a cooking sequence.

2. After laying product in the prescribed method, press

the GREEN ("CANCEL/RAISE") and the BLACK ("STANDBY") buttons at the same time. An audible alert will sound and the platen will lower to the preset gap and the timing will automatically start.

3. When the cook cycle times down to five, (5), seconds remaining, a pre-time-out alarm will sound to alert the grill operator.
4. When the cooking time has been completed, the upper platen will raise and the display will flash "REMOVE" with an audible alert, then remove product per the prescribed method.
5. To cancel a cooking cycle, press the GREEN ("CANCEL/RAISE") button. The upper platen will rise. The display will flash "CANCEL" with an audible alert.

NOTE: If the alarm cancel is set to AUTO, the audible alert will sound five (5) seconds before timing is finished.

-OR-

If the alarm cancel is set to MANUAL, the audible alert will sound as the timing is finished.

To Cook in Flat Grill Mode:

1. SELECT a flat menu by pressing the "MENU SELECT" button, until you attain the required menu item. The display may read either "TOO COOL" or "TOO HOT" (alternating with the "MENU ITEM") until the grill

NORMAL OPERATING MODES

attains the set temperature for that menu.

2. After laying product in the prescribed method, press the GREEN, ("CANCEL/RAISE"), and the BLACK, ("STANDBY"), buttons at the same time, starting the cooking time countdown.

NOTE: If the display reads either "TOO COOL" or "TOO HOT" the controller will not initiate a cooking sequence.

3. PERFORM the required functions displayed, i.e.; sear, turn, to cancel the audible alerts, press the BLACK ("STANDBY") button.

CAUTION: Pressing the GREEN ("CANCEL/RAISE") button will cancel the cooking cycle, and pressing any other button on the controller will cancel the alarm.

4. When the cooking time has been completed, the display will flash "REMOVE" with an audible alert. Remove product per the prescribed method.

NOTE: If a required flat grill menu cannot be found, go to the programming mode (see programming, "MENU ITEMS").

Standby Mode:

1. SELECT a clam grill menu by pressing the "MENU SELECT" button, until you attain the required menu item.

NOTE: If the display reads either "TOO COOL" or "TOO HOT" the upper platen will not go into "STANDBY".

2. PRESS the GREEN ("CANCEL/RAISE") and the BLACK ("STANDBY") buttons at the same time. As soon as the upper platen moves down, release both buttons and press the BLACK ("STANDBY") button again, (within 5 seconds), from the start of a cook cycle, the display will read "STANDBY MODE" alternating with the "MENU ITEM".

EXIT the Standby Mode:

1. PRESS the GREEN ("CANCEL/RAISE") button. The upper platen will raise and the display will read "CANCEL" with an audible alarm.

Standby Alarm (Version 6.20 and higher)

An audible alarm called the "Standby Alarm" has been added to version 6.20 EPROM chip. This alarm, when enabled to "YES" (See Programming - System Setup) will sound if the grill has been idle for 300 seconds (5 minutes) signaling the operator to put the grill into the Standby Mode.

The alarm is INACTIVE if the "Standby Alarm" feature under SYSTEM SETUP is enabled to "NO".

To Display the Current Temperature

1. PRESS the "TEMP" button and repeat for each zone to be displayed.

1st press - CENTER UPPER PLATEN

2nd press - REAR LOWER ZONE

3rd press - FRONT LOWER ZONE

NOTE: The temperatures may be displayed at any time, including during a cooking cycle.

To display all temperature zones at the same time, press the "TEMP" button one, (1), time, then the "PROG" button five (5) times.

To View Settings for a Menu Item:

1. With the required menu displayed, PRESS the "UP ARROW" button (↑).
2. PRESSING the "UP ARROW" button (↑) repeatedly will cycle through and display that menu's function time(s), set temperature(s) and the gap setting (if applicable).

NOTE: The display will return to the menu (menu name) after five (5) seconds if the "UP ARROW" button (↑) has not been pressed.

To Reset Factory Defaults

NOTE: All settings on all menus will revert to factory defaults. It is recommended that all current settings be recorded on paper prior to reloading the factory default settings.

1. PRESS and HOLD the "PROG" button for five, (5), seconds. (Display will flash GC450 and the program version number.
2. PRESS and HOLD the "UP ARROW" button (↑) for twenty, (10), seconds, "RELOAD DEFAULTS" will be displayed.
3. PRESS the "RIGHT ARROW" button (→) to reload. (Display will read "RELOADING DEFAULTS").
4. PRESS the "RIGHT ARROW" (→) to return to the normal OPERATING MODE.

NOTE: Pressing any other button will cancel the RELOAD DEFAULTS request.

NORMAL OPERATING MODES

To Clean the Grill:

1. PRESS the "MENU" button to obtain the menu "CLEAN MODE." (The controls will maintain the proper cleaning temperature).
2. "READY TO CLEAN" will be displayed when the grill is at the proper cleaning temperature and an audible alarm will sound. Press the "MENU" button to display "OFF." The "OFF" position on the controllers allows the operator to raise and lower the upper platens to alternate positions for proper cleaning of the side and rear edges of the platens.
3. When cleaning is completed, you may turn the "MASTER POWER" (rocker) switch off.

NOTE: Be sure to check upper platen safety pin is disengaged (pulled out) prior to pushing grill back under grill.

Breakfast to Lunch Transition (Transition Cooking)

Approximately 30 minutes before changing to the lunch menu, perform the following:

1. PRESS the "TEMP" button (to display the upper platen temperature).
2. Press the "UP ARROW" (↑) button.
3. The upper platen indicator will light (AMBER) and maintain the normal operating (set) temperature.

Multi-Stage Cooking

If you have version 7.30 EPROM chip software, your controller is equipped with the new Multi-stage cooking feature.

With Multi-Stage cooking, the product being cooked is cooked using multiple gap settings for a selected period of time.

For example, during 4:1 cooking, the platen would normally gap at a gap setting of .416 (Four-hundred and sixteen thousandths) for the entire length of the cook cycle.

With multi stage cooking, the platen may gap at the beginning of the cook cycle for .416 for only 20 seconds. At the interval of 21 seconds, the gap may change to .400 for another 25 seconds.

At the 46 second interval (in the remove time), the platen may regap at .420.

NOTE: the above mentioned example is IS NOT the McDonalds multi gap formula for 4:1 cooking.

All of the "CLAM" menu items programmed in this 7.30 eprom chip have options to cook using the multi-stage gap feature.

Currently, 10:1 - CLAM, and 4:1 - CLAM are the only menu items with a factory default program with multiple gaps. Please see table to right showing additional stages for these products.

PRODUCT	FUNCTION	TIME	GAP (MULTI ACTIVE)	TOAST BUNS TIME	TOP TEMP	BOTTOM TEMP
10:1 - CLAM	REMOVE IN	37	.265	0	425°F 218°C	350°F 177°C
	STAGE #1	5	.245			
	STAGE #2	0	0			
	STAGE #3	0	0			
4:1	REMOVE IN	107	.425	0	425°F 277°C	350°F 177°C
	STAGE #1	10	.400			
	STAGE #2	0	0			
	STAGE #3	0	0			

THE TABLE ABOVE REPRESENTS THE 2 MENU ITEMS THAT HAVE A FACTORY DEFAULT SETTING FOR MULTI STAGE COOKING.

*** ONLY AVAILABLE IN 7.XX ***

FOR INFORMATION REGARDING ALL MENU ITEMS, AND THEIR DETAILED LISTING OF FUNCTIONS, SEE "CONTROLLER MENU ITEMS"

PROGRAM LOGIC CHART

The diagram below is a graphical representation of the control's menu structure in the program modes. The following pages detail the various programming procedures. After you become more familiar with these procedures, this diagram will serve as a quick reference to the program functions and the key sequences needed to access them.

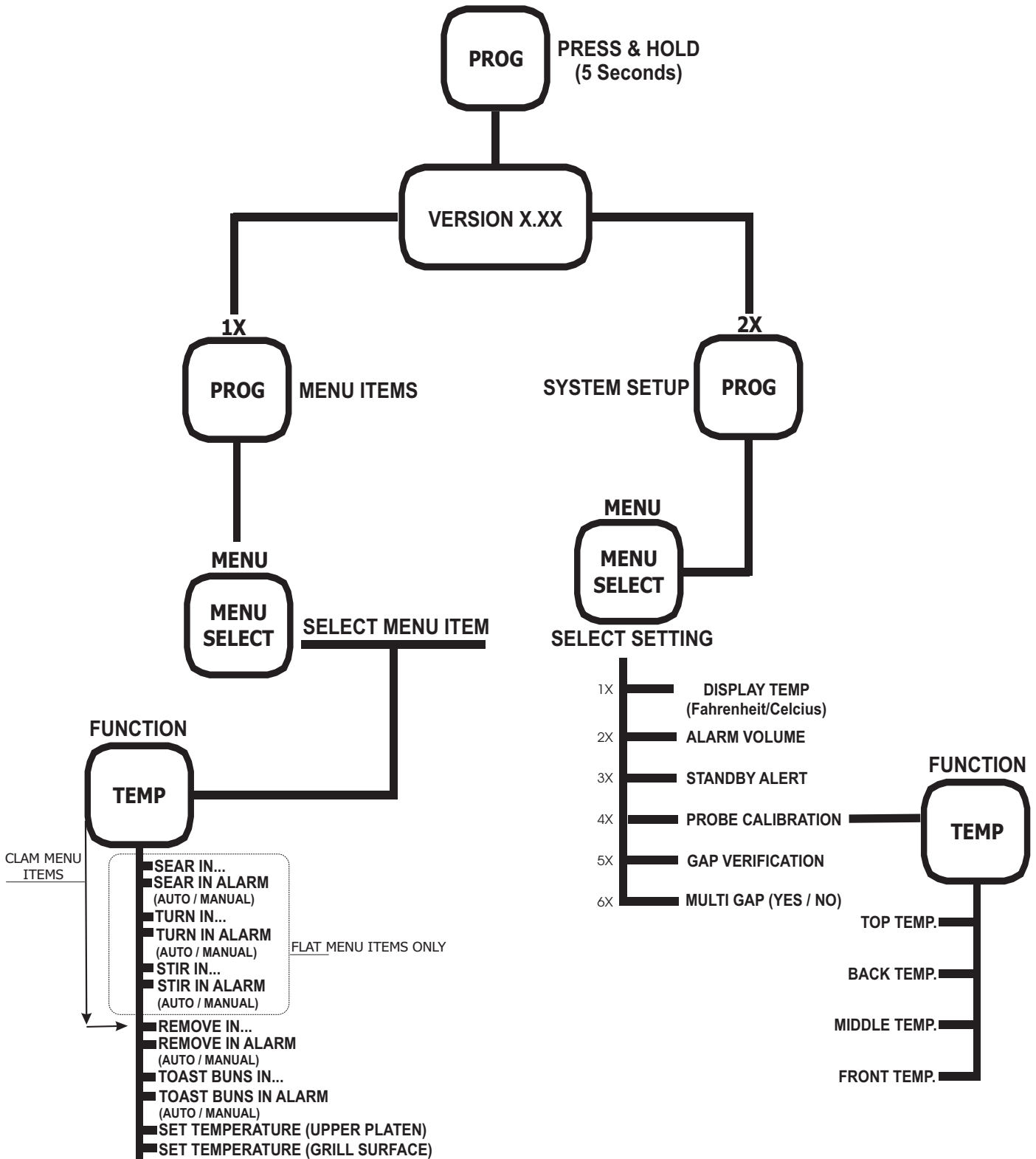

PROGRAMMING

SYSTEM SETUP

To Display Temperatures in F or C

1. **PRESS** and **HOLD** the “**PROG**” button for **five, (5), seconds**. (Display will flash GC450 and the program version number).
2. **PRESS** the “**PROG**” button **twice** to display “**SYSTEM SETUP**”.
3. **PRESS** the “**MENU**” button to display “**DISPLAY TEMP. IN : °F/°C**”.
4. **PRESS** the “**UP ARROW**” button (↑) to change °F or °C.
5. **PRESS** the “**PROG**” button to display “**SYSTEM SETUP**”.
6. **PRESS** the “**RIGHT ARROW**” button (→) to **return to the normal OPERATING MODE**.

To Change the Speaker Volume (High / Low)

1. **PRESS** and **HOLD** the “**PROG**” button for **five, (5), seconds**. (Display will flash GC450 and the program version number).
2. **PRESS** the “**PROG**” button **twice** to display “**SYSTEM SETUP**”.
3. **PRESS** the “**MENU**” button to display “**ALARM VOLUME**”.
4. **PRESS** the “**UP ARROW**” button (↑) to **change (HIGH/LOW)**.
5. **PRESS** the “**PROG**” button to display “**SYSTEM SETUP**”.
6. **PRESS** the “**RIGHT ARROW**” button (→) to **return to the normal OPERATING MODE**.

To Change the Gap Calibration

1. **PRESS** and **HOLD** the “**PROG**” button for **five, (5), seconds**. (Display will flash GC450 and the program version number).
2. **PRESS** the “**PROG**” button **twice** to display “**SYSTEM SETUP**”.
3. **PRESS** and **HOLD** the “**UP ARROW**” (↑) button for **ten, (10), seconds**, “**GAP CALIBRATION**” will be displayed.
4. **PRESS** the “**UP ARROW**” button (↑) again, the “**+**” (**PLUS**) button **to increase** the value **OR** the “**RIGHT ARROW**” button (→), “**-**” (**MINUS**) **to decrease** the value.
5. **PRESS** the “**PROG**” button to display “**SYSTEM SETUP**”.
6. **PRESS** the “**RIGHT ARROW**” button (→), **to return to the normal OPERATING MODE**.

To Enable / Disable Start Delay

1. **PRESS** and **HOLD** the “**PROG**” button for **five, (5), seconds**. (Display will flash GC450 and the program version number).
2. **PRESS** the “**PROG**” button **twice** to display “**SYSTEM SETUP**”.
3. **PRESS** and **HOLD** the “**UP ARROW**”(↑) button for **ten, (10), seconds**, “**GAP CALIBRATION**” will be displayed.
4. **PRESS** the “**MENU**” button. The hold feature will display “**OFF**”.
5. **HOLD** the “**RIGHT ARROW**” (→) for **ten, (10), seconds**, the “**OFF WILL FLASH**”.
6. **PRESS** the “**UP ARROW**” (↑) to change the safety (ON/OFF).
7. **PRESS** the “**PROG**” button to display “**SYSTEM SETUP**”.
8. **PRESS** the “**RIGHT ARROW**” button (→) to **return to the normal OPERATING MODE**.

PROGRAMMING

SYSTEM SETUP

To Change Start Delay Timer

1. PRESS and HOLD the "PROG" button for five, (5), seconds. (Display will flash GC450 and the program version number).
2. PRESS the "PROG" button twice to display "SYSTEM SETUP".
3. PRESS and HOLD the "UP ARROW"(↑) button for ten, (10), seconds, "GAP CALIBRATION" will be displayed.
4. PRESS the "MENU" button. The hold feature will display "OFF".
5. HOLD the "RIGHT ARROW" (→) for ten, (10), seconds, the "(ON / OFF) WILL FLASH".
6. PRESS the "UP ARROW" (↑) to change the safety (ON/OFF).
7. PRESS the "FUNCTION" button to display "DELAY TIME:"
8. PRESS the "UP ARROW" (↑) to change the delay time seconds in increments of .5 seconds.
9. PRESS the "PROG" button to display "SYSTEM SETUP".
10. PRESS the "RIGHT ARROW" button (→) to return to the normal OPERATING MODE.

To Change the Standby Alert Feature - EPROM Chip Ver. 6.20 and higher

1. PRESS and HOLD the "PROG" button for five, (5), seconds. (Display will flash GC450 and the program version number).
2. PRESS the "PROG" button twice to display "SYSTEM SETUP".
3. PRESS the "MENU" button until "STANDBY ALERT (YES/NO)".
4. PRESS the "UP ARROW" button (↑) to change (YES/NO).
5. PRESS the "PROG" button to display "SYSTEM SETUP".
6. PRESS the "RIGHT ARROW" button (→) to return to the normal OPERATING MODE.

To Enable / Disable Multi-Stage Cooking - EPROM Chip Ver. 7.XX and higher

1. PRESS and HOLD the "PROG" button for five, (5), seconds. (Display will flash GC450 and the program version number).
2. PRESS the "PROG" button twice to display "SYSTEM SETUP".
3. PRESS the "MENU" button until "MULTI GAP CLAM" is displayed.
4. PRESS and HOLD the "RIGHT ARROW" button (→) until the (YES/NO) begins to flash.
5. PRESS the "UP ARROW" button (↑) to change "YES" to "NO" or "NO" to "YES".
6. PRESS the "PROG" button
7. PRESS the "RIGHT ARROW" button (→) to return to the normal OPERATING MODE.

NOTE: To Determine your version EPROM chip. PRESS and HOLD the PROG button for approximately 5 seconds. The controller will flash "GC450 - V. X.XX". Eprom Chips are available by calling your local factory authorized service center.

PROGRAMMING

MENU ITEMS

To Add or Delete a Menu Item

1. **PRESS** and **HOLD** the “**PROG**” button for **five, 5 seconds**. (Display will flash GC450 and the program version number).
2. **PRESS** the “**PROG**” button **one time** to display “**MENU ITEMS**”.
3. **PRESS** the “**MENU**” button to display the menu you want to add/delete.
4. **PRESS** the “**UP ARROW**” button (↑) to change “**Y**” or “**N**”.
5. **PRESS** the “**PROG**” button to display “**MENU ITEMS**”.
6. **PRESS** the “**RIGHT ARROW**” button (→) to return to the normal **OPERATING MODE**.

To Change the Remove Time

1. **PRESS** and **HOLD** the “**PROG**” button for **five, 5 seconds**. (Display will flash GC450 and the program version number).
2. **PRESS** the “**PROG**” button **one time** to display “**MENU ITEMS**”.
3. **PRESS** the “**MENU**” button to display the menu you want to adjust.
4. **PRESS** the “**FUNCTION**” button **one time** to display “**REMOVE IN XXX**”.
5. **PRESS** the “**UP ARROW**” button (↑) to change the value of the flashing digit.
6. **PRESS** the “**RIGHT ARROW**” button (→) to advance the cursor to the right for changing its value.
7. **PRESS** the “**PROG**” button to display “**MENU ITEMS**”.
8. **PRESS** the “**RIGHT ARROW**” button (→) to return to the normal **OPERATING MODE**.

To Change the Remove Time Alarm (Auto/Manual)

1. **PRESS** and **HOLD** the “**PROG**” button for **five, 5 seconds**. The display will flash the version number.
2. **PRESS** the “**PROG**” button **one time** to display “**MENU ITEMS**”.
3. **PRESS** the “**MENU**” button to display the menu you want to adjust.
4. **PRESS** the “**FUNCTION**” button **until** “**REMOVE IN XXX**” is displayed.
5. **PRESS** the “**FUNCTION**” button **1X**. Controller will display “**ALARM (AUTO / MANUAL)**”.
6. **PRESS** the “**UP ARROW**” button (↑) to change the setting (**AUTO/MANUAL**).
7. **PRESS** the “**PROG**” button to display “**MENU ITEMS**”.
8. **PRESS** the “**RIGHT ARROW**” button (→) to return to the normal **OPERATING MODE**.

PROGRAMMING

To Change the Sear Time

The following procedure IS ONLY AVAILABLE and can only be changed in FLAT MENU ITEMS.

1. **PRESS** and **HOLD** the “**PROG**” button for **five, 5 seconds**. The display will flash the version number.
2. **PRESS** the “**PROG**” button **one time** to display “**MENU ITEMS**”.
3. **PRESS** the “**MENU**” button to display the menu you want to adjust.
4. **PRESS** the “**FUNCTION**” button **until** “**SEAR IN XXX**” is displayed on the controller.

NOTE: IF SEAR TIME IS NOT DISPLAYED ON THE CONTROLLER, ENSURE THAT THE CURRENT PRODUCT SELECTED IS A FLAT MENU ITEM.

5. **PRESS** the “**UP ARROW**” button (↑) to change the value of the flashing digit.
6. **PRESS** the “**RIGHT ARROW**” button (→) to advance the cursor to the right for changing its value.
7. **PRESS** the “**PROG**” button to display “**MENU ITEMS**”.
8. **PRESS** the “**RIGHT ARROW**” button (→) to return to the normal **OPERATING MODE**.

To Change the Sear Time Alarm (Auto/Manual)

The following procedure IS ONLY AVAILABLE and can only be changed in FLAT MENU ITEMS.

1. **PRESS** and **HOLD** the “**PROG**” button for **five, 5 seconds**. The display will flash the version number.
2. **PRESS** the “**PROG**” button **one time** to display “**MENU ITEMS**”.
3. **PRESS** the “**MENU**” button to display the menu you want to adjust.
4. **PRESS** the “**FUNCTION**” button **until** “**SEAR IN XXX**” is displayed.

NOTE: IF SEAR IN IS NOT DISPLAYED ON THE CONTROLLER, ENSURE THAT THE CURRENT PRODUCT SELECTED IS A FLAT MENU ITEM

5. **PRESS** the “**FUNCTION**” button 1X. Controller will display “**ALARM (AUTO / MANUAL)**”.

6. **PRESS** the “**UP ARROW**” button (↑) to change the setting (**AUTO/MANUAL**).

7. **PRESS** the “**PROG**” button to display “**MENU ITEMS**”.

8. **PRESS** the “**RIGHT ARROW**” button (→) to return to the normal **OPERATING MODE**.

To Change the Toast Buns Time

1. **PRESS** and **HOLD** the “**PROG**” button for **five, 5 seconds**. The display will flash the version number.

2. **PRESS** the “**PROG**” button **one time** to display “**MENU ITEMS**”.

3. **PRESS** the “**MENU**” button to display the menu you want to adjust.

4. **PRESS** the “**FUNCTION**” button **until** “**TOAST BUNS IN XXX**” is displayed.

5. **PRESS** the “**UP ARROW**” button (↑) to change the value of the flashing digit.

6. **PRESS** the “**RIGHT ARROW**” button (→) to advance the cursor to the right for changing its value.

7. **PRESS** the “**PROG**” button to display “**MENU ITEMS**”.

8. **PRESS** the “**RIGHT ARROW**” button (→) to return to the normal **OPERATING MODE**.

To Change the Toast Buns Alarm (Auto/Manual)

1. **PRESS** and **HOLD** the “**PROG**” button for **five, 5 seconds**. The display will flash the version number.

2. **PRESS** the “**PROG**” button **one time** to display “**MENU ITEMS**”.

3. **PRESS** the “**MENU**” button to display the menu you want to adjust.

4. **PRESS** the “**FUNCTION**” button **until** “**TOAST BUNS IN XXX**” is displayed.

5. **PRESS** the “**FUNCTION**” button 1X until “**ALARM**” is displayed.

6. **PRESS** the “**UP ARROW**” button (↑) to change the setting (**AUTO/MANUAL**).

7. **PRESS** the “**PROG**” button to display “**MENU**”.

PROGRAMMING

MENU ITEMS

ITEMS”.

8. **PRESS** the “**RIGHT ARROW**” button (→) to return to the normal **OPERATING MODE**.

To Change Turn Time

The following procedure IS ONLY AVAILABLE and can only be changed in FLAT MENU ITEMS.

1. **PRESS** and **HOLD** the “**PROG**” button for **five, 5 seconds**. The display will flash the version number.
2. **PRESS** the “**PROG**” button **one time** to display “**MENU ITEMS**”.
3. **PRESS** the “**MENU**” button to display the menu you want to adjust.
4. **PRESS** the “**FUNCTION**” button **until** “**TURN IN XXX**” is displayed on the controller.

NOTE: IF TURN TIME IS NOT DISPLAYED ON THE CONTROLLER, ENSURE THAT THE CURRENT PRODUCT SELECTED IS A FLAT MENU ITEM.

5. **PRESS** the “**UP ARROW**” button (↑) to change the value of the flashing digit.
6. **PRESS** the “**RIGHT ARROW**” button (→) to advance the cursor to the right for changing its value.
7. **PRESS** the “**PROG**” button to display “**MENU ITEMS**”.
8. **PRESS** the “**RIGHT ARROW**” button (→) to return to the normal **OPERATING MODE**.

To Change Turn In Alarm (Auto / Manual)

The following procedure IS ONLY AVAILABLE and can only be changed in FLAT MENU ITEMS.

1. **PRESS** and **HOLD** the “**PROG**” button for **five, 5 seconds**. The display will flash the version number.
2. **PRESS** the “**PROG**” button **one time** to display “**MENU ITEMS**”.
3. **PRESS** the “**MENU**” button to display the menu you want to adjust.

4. **PRESS** the “**FUNCTION**” button **until** “**TURN IN XXX**” is displayed.

NOTE: IF TURN IN IS NOT DISPLAYED ON THE CONTROLLER, ENSURE THAT THE CURRENT PRODUCT SELECTED IS A FLAT MENU ITEM

5. **PRESS** the “**FUNCTION**” button 1X. Controller will display “**ALARM (AUTO / MANUAL)**”.
6. **PRESS** the “**UP ARROW**” button (↑) to change the setting (**AUTO/MANUAL**).
7. **PRESS** the “**PROG**” button to display “**MENU ITEMS**”.
8. **PRESS** the “**RIGHT ARROW**” button (→) to return to the normal **OPERATING MODE**.

To Change the grill surface set temperature

1. **PRESS** and **HOLD** the “**PROG**” button for **five, 5 seconds**. (Display will flash GC450 and the program version number).
2. **PRESS** the “**PROG**” button **one time** to display “**MENU ITEMS**”.
3. **PRESS** the “**MENU**” button to display the menu you want to adjust.
4. **PRESS** the “**FUNCTION**” button **three times** to display “**TOP TEMP**”.
5. **PRESS** the “**UP ARROW**” button (↑) to change the value of the flashing digit.
6. **PRESS** the “**RIGHT ARROW**” button (→) to advance the cursor to the right for changing its value.
7. **PRESS** the “**PROG**” button to display “**MENU ITEMS**”.
8. **PRESS** the “**RIGHT ARROW**” button (→) to return to the normal **OPERATING MODE**.

PROGRAMMING

MENU ITEMS

To Change the upper platen set temperature

1. **PRESS** and **HOLD** the “**PROG**” button for **five, 5 seconds**. (Display will flash GC450 and the program version number).
2. **PRESS** the “**PROG**” button **one time** to display “**MENU ITEMS**”.
3. **PRESS** the “**MENU**” button to display the menu you want to adjust.
4. **PRESS** the “**FUNCTION**” button **four times** to display “**BOTTOM TEMP XXX**”
5. **PRESS** the “**UP ARROW**” button (↑) to change the value of the flashing digit.
6. **PRESS** the “**RIGHT ARROW**” button (→) to advance the cursor to the right for changing its value.
7. **PRESS** the “**PROG**” button to display “**MENU ITEMS**”.
8. **PRESS** the “**RIGHT ARROW**” button(→) to return to the normal **OPERATING MODE**.

To Enable High Limit Test - GRILL SURFACE (Chip V. 3.52 and 4.0* ONLY)

1. **PRESS** and **HOLD** the “**PROG**” button for **five, 5 seconds**. (Display will flash GC450 and the program version number).
2. **PRESS** the “**PROG**” button **one time** to display “**MENU ITEMS**”.
3. **PRESS** the “**MENU**” button to display “**HIGH LIMIT GRILL**”.
4. **PRESS** the “**UP ARROW**” button (↑) to change “**Y**” or “**N**”.
5. **PRESS** the “**PROG**” button to display “**MENU ITEMS**”.
6. **PRESS** the “**RIGHT ARROW**” button (→) to return to the normal **OPERATING MODE**.

To Enable High Limit Test - PLATEN (Chip V. 3.52 and 4.0* ONLY)

1. **PRESS** and **HOLD** the “**PROG**” button for **five, 5 seconds**. (Display will flash GC450 and the program version number).
2. **PRESS** the “**PROG**” button **one time** to display “**MENU ITEMS**”.
3. **PRESS** the **MENU** button to display “**HIGH LIMIT PLATEN**”.
4. **PRESS** the **UP ARROW** (↑) to change “**Y**” to “**N**” or “**N**” to “**Y**”.
5. **PRESS** the **PROG** button to display “**MENU ITEMS**”.
6. **PRESS** the **RIGHT ARROW** button (→) to return to the normal operating mode.

PROGRAMMING

MENU ITEMS

TO ADD / PROGRAM NEW MENU ITEMS

To Add / Program an [Option Menu - CLAM]

1. **PRESS** and **HOLD** the “**PROG**” button for **five, (5), seconds**. (Display will flash GC450 and the program version number).
2. **PRESS** the “**PROG**” button **twice** to display “**SYSTEM SETUP**.”
3. **PRESS** and **HOLD** the “**UP ARROW**” button (↑) for **ten (10) seconds**, “**GAP CALIBRATION**” will be displayed.
4. **PRESS** the “**PROG**” button **twice** to display “**MENU ITEMS**.”
5. **PRESS** the “**MENU**” button to display “**OPTIONAL MENU (1)(2)(3) Clam**”.
6. **PRESS** the “**UP ARROW**” button (↑) to change “**Y/N**”.
7. **PRESS** the “**FUNCTION**” button to obtain “**REMOVE IN XXX**”.
8. **PRESS** the “**UP ARROW**” button (↑) to **obtain the desired number (0 - 9)**.
9. **PRESS** the “**RIGHT ARROW**” button (→) to **move the cursor**, (blinking digit), to the required digit position.
10. **PRESS** the “**FUNCTION**” button to display “**ALARM**”.
11. **PRESS** the “**UP ARROW**” button (↑) to change the setting (**AUTO/MANUAL**).
12. **PRESS** the “**FUNCTION**” button to display “**TOP TEMP**”. Top Temp. Default = OFF.
13. **PRESS** the “**UP ARROW**” button (↑) to change the value of the flashing digit.
14. **PRESS** the “**RIGHT ARROW**” button (→) to advance the cursor to the right for changing its value.
15. **PRESS** the “**FUNCTION**” button to display “**BOTTOM TEMP XXX**”. Bottom Temp. Default = OFF.
16. **PRESS** the “**UP ARROW**” button (↑) to change the value of the flashing digit.
17. **PRESS** the “**RIGHT ARROW**” button (→) to advance the cursor to the right for changing its value.
18. **PRESS** the “**FUNCTION**” button to obtain “**GAP SETTING**”.
19. **PRESS** the “**UP ARROW**” button (↑) to change the value of the flashing digit.
20. **PRESS** the “**RIGHT ARROW**” button (→) to advance the cursor to the right for changing its value.
21. **PRESS** the “**FUNCTION**” button to obtain display “**OPTIONAL MENU CLAM**”. To Label the New menu:
22. **PRESS** the “**UP ARROW**” button (↑) to change the value of the flashing digit.
23. **PRESS** the “**RIGHT ARROW**” button (→) to advance the cursor to the right for changing its value. (Alpha-numeric capabilities).
24. **PRESS** the “**PROG**” button to display “**MENU ITEMS**”.
25. **PRESS** the “**RIGHT ARROW**” button (→) to return to the normal **OPERATING MODE**.

PROGRAMMING

MENU ITEMS

To Add / Program an [OPTION MENU - FLAT]

- 1. PRESS and HOLD** the “**PROG**” button for **five, (5), seconds**. (Display will flash GC450 and the program version number).
- 2. PRESS** the “**PROG**” button **once** to display “**MENU ITEMS.**”
- 3. PRESS** the “**MENU**” button to display “**OPTIONAL MENU (1)(2)(3) Flat.**”
- 4. PRESS** the “**UP ARROW**” button (↑) to change “**Y/N.**”
- 5. PRESS** the “**FUNCTION**” button to obtain “**SEAR IN XXX.**”
- 6. PRESS** the “**UP ARROW**” button (↑) to obtain the desired number (O - 9).
- 7. PRESS** the “**RIGHT ARROW**” button (→) to move the cursor, (blinking digit), to the required digit position.
- 8. PRESS** the “**FUNCTION**” button to display “**ALARM.**”
- 9. PRESS** the “**UP ARROW**” button (↑) to change the setting (**AUTO/MANUAL**).
- 10. PRESS** the “**FUNCTION**” button to obtain “**TURN IN XXX.**”
- 11. PRESS** the “**UP ARROW**” button (↑) to obtain the desired number (O - 9).
- 12. PRESS** the “**RIGHT ARROW**” button (→) to move the cursor, (blinking digit), to the required digit position.
- 13. PRESS** the “**FUNCTION**” button to display “**ALARM.**”
- 14. PRESS** the “**UP ARROW**” button (↑) to change the setting (**AUTO/MANUAL**).
- 15. PRESS** the “**FUNCTION**” button to display “**REMOVE IN.**”
- 16. PRESS** the “**UP ARROW**” button (↑) to obtain the desired number (O - 9).
- 17. PRESS** the “**RIGHT ARROW**” button (→) to move the cursor, (blinking digit), to the required digit position.
- 18. PRESS** the “**FUNCTION**” button to display “**ALARM.**”
- 19. PRESS** the “**UP ARROW**” button (↑) to change the setting (**AUTO/MANUAL**).
- 20. PRESS** the “**FUNCTION**” button to display “**TOP TEMP.** Flat Mode Top Temp is set to **OFF.**”
- 21. PRESS** the “**FUNCTION**” button to display “**BOTTOM TEMP XXX.** Bottom Temp. Default = **OFF.**”
- 22. Press** the “**UP ARROW**” button (↑) to change the value of the flashing digit.
- 23. PRESS** the “**RIGHT ARROW**” button (→) to advance the cursor to the right for changing its value.
- 24. PRESS** the “**FUNCTION**” button to obtain display “**OPTIONAL MENU FLAT.**” To Label the New menu:
- 25. PRESS** the “**UP ARROW**” button (↑) to change the value of the flashing digit.
- 26. PRESS** the “**RIGHT ARROW**” button (→) to advance the cursor to the right for changing its value. (Alpha-numeric capabilities).
- 27. PRESS** the “**PROG**” button to display “**MENU ITEMS.**”
- 28. PRESS** the “**RIGHT ARROW**” button (→) to return to the normal **OPERATING MODE.**

PROBE CALIBRATION

MWG-9501, MWGH-9501 (FULL SIZE & HALF SIZE UNITS WITH 3 ZONES PER HALF)

THIS CALIBRATION PROCESS SHOULD BE DONE BI-WEEKLY

Bi-Weekly Calibration of Grill Temperature Zones

Tools: Digital Pyrometer with Surface Probe

Warning: PERSONAL INJURY FROM BURNS MAY RESULT WHEN COMING IN CONTACT WITH HOT COOKING SURFACES.

NOTE: Calibration of grills is done with release material sheets "OFF".

PLEASE READ THESE INSTRUCTIONS FULLY and note some important items regarding the 7.** Eprom Chip.

1. The upper platens and lower grill plate should be at operating temperatures to perform this calibration procedure. Press the "MENU" button to select a "CLAM" operation and allow the grill to reach the set temperature and stabilize, (approximately 30 minutes).
2. Press and hold the "PROG" button for 5 seconds to enter the program mode, then press "PROG" button (2) times to access the "SYSTEM SETUP".
3. Under "SYSTEM SETUP", press the "MENU" button until "PROBE CALIBRATION" is displayed on the controller.
4. Press the "FUNCTION" button to display the first zone to be calibrated. The first zone displayed is "TOP TEMP - XXX". The zones are displayed in order of TOP, BACK, and FRONT.

The grill's thermocouple probes are located front to rear, as

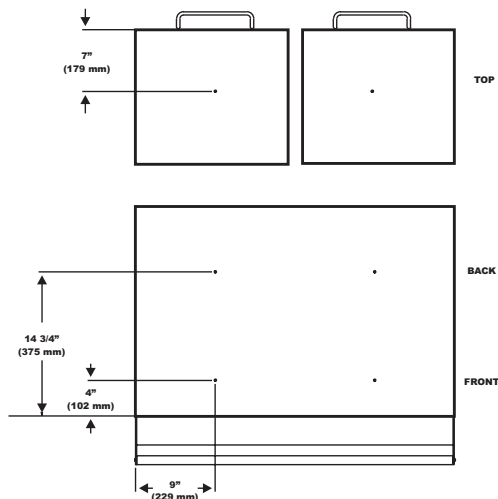
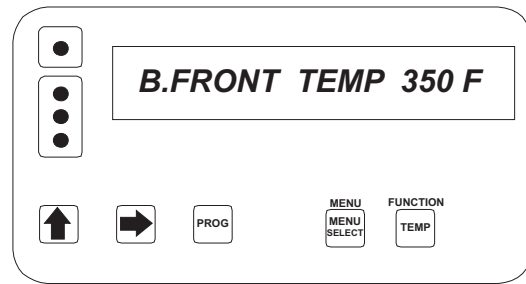

Figure 3 - FULL size gas thermocouple locations



shown in Figure 3, on each half of the lower grill plate in the center of the cooking zone. Each upper platen has one thermocouple in the center.

5. Select a heat zone display, and then place the surface probe of the digital pyrometer directly on the grill at the same heat zone.
6. Allow at least 5 seconds for the pyrometer to respond and stabilize. Note the temperature on the pyrometer.

NOTE: Eprom Chip Version 7.** has a special feature for Probe Calibration. To ensure that the calibration is done correctly, and at the best time, the controller has a special alarm that will sound when the grill is ready for calibration. If the alarm is not sounding, then the controller will NOT allow the operator to calibrate the grill. It is important to wait until the alarm sounds before any adjustment of temperature is attempted.

7. If the temperature on the grill control display does not match the temperature on the pyrometer, adjust the temperature on the grill control accordingly. The "UP ARROW" button will increase the displayed temperature in one, (1) degree increments. The "RIGHT ARROW" button will decrease the displayed temperature in one, (1), degree increments.
8. Press the "FUNCTION" button to select the next heat zone.
9. Move the pyrometer's surface probe to the newly selected heat zone and repeat steps 6 and 7 above.
10. Repeat the procedure for each of the heat zones.
11. Continue to cycle through each heat zone repeatedly until all temperatures are within 1 degree.
12. Exit the program mode by pressing the "PROG" button, then the "RIGHT ARROW" button. This will return the grill to the clam mode originally chosen.

PROBE CALIBRATION

MWGF-9501, MWGFH-9501 (FULL SIZE & HALF SIZE FLAT UNITS WITH 2 ZONES PER HALF)

THIS CALIBRATION PROCESS SHOULD BE DONE BI-WEEKLY

Bi-Weekly Calibration of Grill Temperature Zones

Tools: Digital Pyrometer with Surface Probe

Warning: PERSONAL INJURY FROM BURNS MAY RESULT WHEN COMING IN CONTACT WITH HOT COOKING SURFACES.

NOTE: Calibration of grills is done with release material sheets “OFF”.

PLEASE READ THESE INSTRUCTIONS FULLY and note some important items regarding the 7.** Eprom Chip.

1. The upper platens and lower grill plate should be at operating temperatures to perform this calibration procedure. Press the “MENU” button to select a “CLAM” operation and allow the grill to reach the set temperature and stabilize, (approximately 30 minutes).
2. Press and hold the “PROG” button for 5 seconds to enter the program mode, then press “PROG” button (2) times to access the “SYSTEM SETUP”.
3. Under “SYSTEM SETUP”, press the “MENU” button until “PROBE CALIBRATION” is displayed on the controller.

NOTE: The upper platen is still exists in the controller. Even though the upper platen does not exist, IT IS IMPERATIVE that the upper platen heat zone is calibrated.

IMPORTANT: THE UPPER PLATEN SHOULD BE CALIBRATED UTILIZING THE BACK ZONE AS ITS HEAT ZONE. When the controller reads “Top Temp – XXXF”, your pyrometer should be on the BACK HEAT ZONE. The next zone displayed is “B. Back Temp – XXXF”, your pyrometer WILL REMAIN in the back zone. Proceed to the other heat zones.

4. Press the “FUNCTION” button to display the first zone to be calibrated. The first zone displayed is “TOP TEMP – XXX”. The zones are displayed in order of TOP, BACK, and FRONT.

The grill’s thermocouple probes are located front to rear, as shown in Figure 4, on each half of the lower grill plate in the center of the cooking zone. Each upper platen has one thermocouple in the center.

5. Select a heat zone display, and then place the surface probe of the digital pyrometer directly on the grill at the same heat zone.
6. Allow at least 5 seconds for the pyrometer to respond and stabilize. Note the temperature on the pyrometer.

NOTE: Eprom Chip Version 7.** has a special feature for Probe Calibration. To ensure that the calibration is done correctly, and at the best time, the controller has a special alarm that will sound when the grill is ready for calibration. If the alarm is not sounding, then the controller will NOT allow the operator to calibrate the grill. It is important to wait until the alarm sounds before any adjustment of temperature is attempted.

7. If the temperature on the grill control display does not match the temperature on the pyrometer, adjust the temperature on the grill control accordingly. The “UP ARROW” button will increase the displayed temperature in one, (1) degree increments. The “RIGHT ARROW” button will decrease the displayed temperature in one, (1), degree Increments.
8. Press the “FUNCTION” button to select the next heat zone.
9. Move the pyrometer’s surface probe to the newly selected heat zone and repeat steps 6 and 7 above.
10. Repeat the procedure for each of the heat zones.
11. Continue to cycle through each heat zone repeatedly until all temperatures are within 1 degree.
12. Exit the program mode by pressing the “PROG” button, then the “RIGHT ARROW” button. This will return the grill to the clam mode originally chosen.

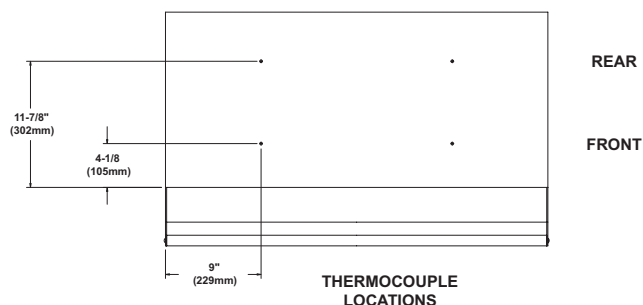
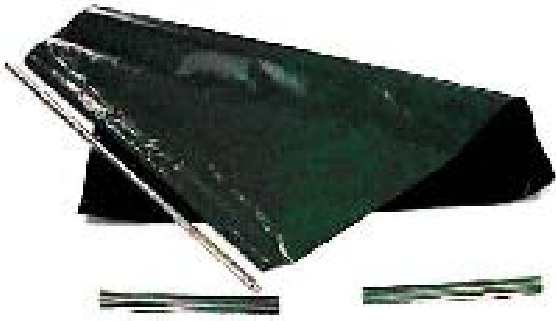

Figure 4 - FULL size gas FLAT thermocouple locations

OPTIONAL ACCESSORIES



Teflon Sheet - 1799301
Teflon Rear Rod - 1851201
Teflon Clip - 1851301



Teflon Rollup Assembly
Left Assy - 1853799
Reight Assy - 1853798

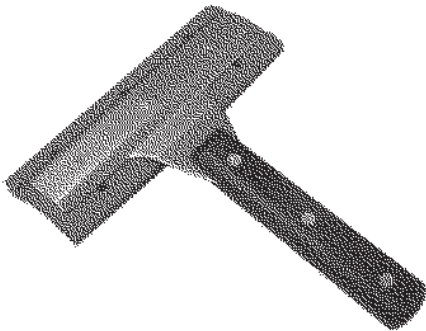

Grill Squeegee - 1858201



Splash Shield - 1873703

TROUBLESHOOTING

POSSIBLE ERROR MESSAGES

"Probe Open"

An open probe condition has occurred. The controller will turn the heater controlled by the malfunctioning probe OFF. If the open probe condition should correct itself; the control will return to the "IDLE MODE".

"Clam did not go down"

Occurs if the platen does not reach the proper position (GAP SETTING) in 30 seconds. You may cancel the message by pressing the "TEMP" button.

"Upper Platen Stuck"

Occurs when the controller does not get an upper platen setting signal 15 seconds after it starts to raise the platen. In order to return to the "IDLE MODE", the controller must get a upper platen setting signal. You may cancel the message by pressing the "TEMP" button followed by the GREEN ("RAISE") button in order to retry raising the platen.

"Eprom Corrupt"

Displayed at startup when the controller detects a corrupt menu item or when a new version of the software is loaded. To cancel this message, switch the grill "off" and "on" again at the main power switch.

"Ignition Failure"

Occurs when the system has tried to ignite the gas burner (4) FOUR times, and has failed.

"High Limit"

Occurs when:

1. The Controller senses a zone at 465(F (241(C)

NOTE: The Controller has 2 High Limit tests located at the end of the menu item list. If the test is enabled, that test will heat the zone (Platen, or Grill) to 465(, and the controller will flash "High Limit"

"Motor Overcurrent"

Occurs when:

1. The upper platen has been mechanically resisted the platen will stop.
2. The platen control motor is inoperative. Turn the "MASTER POWER" switch OFF, then ON again.

"Faulty Element / Shorted Probe"

Occurs when the controller does not detect a proper temperature response. Also, the RED LED will light, indicating which element /probe is in error.

NOTE: Should all four, (4), LED's flash RED approximately six, (6), minutes after the unit is turned on, ensure that the main three-phase, (large), power cord is plugged in and the main circuit breaker is ON.

TROUBLESHOOTING

In Store Troubleshooting Guide

Controller Displays "EEPROM CORRUPT"	<ol style="list-style-type: none"> 1. New Version EPROM Chip? 2. Faulty EPROM Chip or Faulty Controller. 	<ol style="list-style-type: none"> 1. Re-initialize Unit 2. CALL FOR SERVICE
Platen Will Not Come Down	<ol style="list-style-type: none"> 1. Grill Has Not Reached Set Temperature Yet. 2. Upper Platen Locking Pin is Engaged 3. Press the GREEN Pushbutton, and then the BLACK Pushbutton. Do they beep separately? 	<ol style="list-style-type: none"> 1. Allow grill to reach set temperature. 2. Pull out Upper Platen Locking Pin. 3. Either Yes or No, CALL FOR SERVICE
Controller Displays "TOO HOT"	<ol style="list-style-type: none"> 1. Current Selected Menu Item requires a lower set point temperature than the one previously selected. 2. One or more heat zones have exceeded the set point temperatures by 79°F (27°C). 3. Temperature is continuing to rise? 	<ol style="list-style-type: none"> 1. Allow grill to cool down to current menu items set point temperature. 2. NOTE HEAT ZONE (RED LED LIGHT) and CALL FOR SERVICE. 3. CALL FOR SERVICE
Controller displays "MOTOR OVERCURRENT"	<ol style="list-style-type: none"> 1. Turn Main Power Switch OFF, wait 5 seconds, and turn back on to reinitialize controllers. 2. Problem happens only in the morning? 	<ol style="list-style-type: none"> 1. Possible frequency interruption. Monitor for repetitive error. 2. Possible Preventative Maintenance Needed. 3. CALL FOR SERVICE
Controller displays "FAULT ELEMENT or SHORTED PROBE"	<ol style="list-style-type: none"> 1. Are all LED lights flashing RED, both sides or either sides? 2. 1 – 3 zones flashing RED? 	<ol style="list-style-type: none"> 1. Check to make sure that ALL power cords are plugged in properly. Electric grills have 3 cords. CHECK CIRCUIT BREAKERS. 2. NOTE ZONE AND CALL FOR SERVICE. 3. CALL FOR SERVICE
Controller Displays "OPEN PROBE"	<ol style="list-style-type: none"> 1. During Initialization? 2. During Cooking 	<ol style="list-style-type: none"> 1. NOTE ZONE AND CALL FOR SERVICE – Possible Thermocouple, Interface Board or Controller. 2. Zone(s) became too hot. NOTE ZONE AND CALL FOR SERVICE. Possible Solid State Relay, Thermocouple, Thermocouple Interface Boards, or Controller.
Controller Displays "HIGH LIMIT"	<ol style="list-style-type: none"> 1. Test is in Progress and heated to 465° (241°). 2. Zone(s) became too hot. Tests are not active. 3. Possible Frequency Interruption. 	<ol style="list-style-type: none"> 1. Turn Grill off and wait 5 minutes for grill to cool down. Disable Test. 2. CALL FOR SERVICE. 3. CALL FOR SERVICE.
Controller Displays "Ignition Failure"	<ol style="list-style-type: none"> 1. Is Gas line connected properly underneath grill? 2. Is gas shutoff handle on gas hose in the correct position and in the "ON" position. ("ON" is when the handle is parallel to the hose) 	<ol style="list-style-type: none"> 1. Disconnect and reconnect gas line. 2. Turn the valve handle to the "ON" position. 3. CALL FOR SERVICE

NOTES

Lined area for taking notes, consisting of multiple horizontal lines across the page.

CONTROLLER MENU ITEMS

THE FOLLOWING TABLE LISTS MENU ITEMS DEFAULTED IN THE MAIN CONTROLLER AS NEW. TO REPROGRAM ANY FUNCTION OR FEATURE BELOW, SEE PROGRAMMING.

** THE MENU ITEMS LISTED BELOW ARE FOR EPROM CHIP VERSIONS UP TO 6.20 - FOR EPROM CHIP VERSION 7.XX, PLEASE SEE THE FOLLOWING TABLE FOR MORE INFORMATION **

** TO IDENTIFY YOUR EPROM CHIP, PRESS AND HOLD THE PROG BUTTON THE CONTROLLER **

Eprom Chip				Menu Item Name	Function (Duty)	Time (Secs)	Set Temp		Set Temp		Gap Setting
Version #							(F)	(C)			
3.01	3.52	4.00 4.01 4.02	6.20				Lower	Upper	Lower	Upper	
YES	YES	YES	YES	OFF (Always first)	NONE	NONE	OFF	OFF	OFF	OFF	.090
				6.20 Chip & Higher --->							.083
NO	NO	NO	YES	Preheat	"Ready to Cook"	NONE	350	425	177	218	.083
YES	YES	YES	YES	10:1 - CLAM	Remove	36	350	425	177	218	.255
				6.20 Chip & Higher --->	Toast Buns	0					
YES	YES	YES	YES	4:1 - CLAM	Remove	104	350	425	177	218	.415
				6.20 Chip & Higher --->	Toast Buns	0					
YES	YES	YES	NO	Circular Bacon - CLAM	Remove	88	325	400	163	204	.090
NO	NO	NO	YES	Strip Bacon - CLAM	Remove	23	350	425	177	218	.090
YES	YES	YES	NO	Sausage - CLAM (THD)	Remove	48	325	400	163	204	.350
YES	YES	YES	YES	Sausage - CLAM (FRZ)	Remove	82	350	425	177	218	.350
YES	YES	YES	YES	McRib - CLAM	Remove	163	350	425	177	218	.530
NO	NO	YES	YES	Steak - CLAM	Remove	82	350	425	177	218	.415
YES	YES	NO	NO	Grilled Chicken - FLAT	Turn	115	350	425	177	218	NONE
					Remove	230					
NO	NO	YES	YES	Grilled Chicken - FLAT	Turn	195	350	425	177	218	NONE
					Remove	410					
YES	YES	YES	YES	Folded Eggs - FLAT	Remove	35	265	OFF	130	OFF	NONE
YES	YES	YES	NO	Canadian Bacon - FLAT	Turn	10	265	OFF	130	OFF	NONE
					Remove	20					
YES	YES	YES	YES	Round Eggs	Remove	150	265	OFF	130	OFF	NONE
NO	NO	NO	YES	Chick F Bread - FLAT	Remove	100	350	425	177	218	NONE
YES	YES	YES	YES	10:1 - FLAT	Sear	20	340	OFF	171	OFF	NONE
					Turn	75					
					Remove	125					
YES	YES	YES	YES	4:1 - FLAT	Sear	20	365	OFF	185	OFF	NONE
					Turn	150					
					Remove	270					
YES	YES	YES	YES	McRib - FLAT	Turn	270	365	OFF	185	OFF	NONE
					Remove	390					

CONTROLLER MENU ITEMS

YES	YES	YES	NO	Sausage - FLAT (THD)	Turn/Sear	90	365	OFF	185	OFF	NONE
					Remove	180					
YES	YES	YES	YES	Sausage - FLAT (FRZ)	Turn/Sear	150	365	OFF	185	OFF	NONE
					Remove	270					
YES	YES	YES	YES	Hotcakes - FLAT	Turn	90	365	OFF	185	OFF	NONE
					Remove	140					
YES	YES	YES	NO	Ham - FLAT	Turn	30	365	OFF	185	OFF	NONE
					Remove	60					
YES	YES	YES	NO	Sausage Burrito - FLAT	Stir	90	365	OFF	185	OFF	NONE
					Remove	180					
YES	YES	YES	YES	Option Menu 1 - CLAM	Remove	0	0	0	0	0	.469
YES	YES	YES	YES	Option Menu 2 - CLAM	Remove	0	0	0	0	0	.250
YES	YES	NO	YES	Option Menu 3 - CLAM	Remove	0	0	0	0	0	.250
NO	NO	NO	YES	Option Menu 4 - CLAM	Remove	0	0	0	0	0	.250
				--- through ---							
NO	NO	NO	YES	Option Menu 20 - CLAM	Remove	0	0	0	0	0	.250
YES	YES	YES	YES	Option Menu 1 - FLAT	Turn/Sear/ Remove	0	0	0	0	0	NONE
YES	YES	NO	YES	Option Menu 2 - FLAT	Turn/Sear/ Remove	0	0	0	0	0	NONE
YES	YES	NO	YES	Option Menu 3 - FLAT	Turn/Sear/ Remove	0	0	0	0	0	NONE
				--- through ---							
NO	NO	NO	YES	Option Menu 8 - FLAT	Turn/Sear/ Remove	0	0	0	0	0	NONE

CONTROLLER MENU ITEMS (EPROM CHIP VER. 7.XX)

ITEM	ACTIVE	FUNCTION	TIME	ALARM	GAP (NON-MULTI)	GAP (MULTI)	MUST REMOVE TIME	TOAST BUNS TIME	TOAST BUNS ALARM	TOP TEMP (F)	BOTTOM TEMP (F)
OFF	YES(ONLY)	NONE	NONE	NONE	.083	.083	NONE	NONE	NONE	OFF	OFF
PREHEAT	YES(ONLY)	READY TO COOK	NONE	NONE	.083	.083	NONE	NONE	NONE	425	350
10:1-CLAM	YES	REMOVE IN	37	AUTO	.255	.265	0	0	AUTO	425	350
		STAGE # 1	5	NONE	---	.245					
		STAGE # 2	0	NONE	---	0					
		STAGE # 3	0	NONE	---	0					
4:1-CLAM	YES	REMOVE IN	107	AUTO	.415	.425	0	0	AUTO	425	350
		STAGE # 1	10	NONE	---	.400					
		STAGE # 2	0	NONE	---	0					
		STAGE # 3	0	NONE	---	0					
STRIP BACON-CLAM	YES	REMOVE IN	23	AUTO	.089	.089	NONE	NONE	NONE	425	350
		STAGE # 1	0	NONE	---	0					
		STAGE # 2	0	NONE	---	0					
		STAGE # 3	0	NONE	---	0					
SAUSAGE-CLAM FZN	YES	REMOVE IN	82	AUTO	.350	.350	NONE	NONE	NONE	425	350
		STAGE # 1	0	NONE	---	0					
		STAGE # 2	0	NONE	---	0					
		STAGE # 3	0	NONE	---	0					
McRIB-CLAM	NO	REMOVE IN	163	AUTO	.530	.530	NONE	NONE	NONE	425	350
		STAGE # 1	0	NONE	---	0					
		STAGE # 2	0	NONE	---	0					
		STAGE # 3	0	NONE	---	0					
STEAK-CLAM	YES	REMOVE IN	104	AUTO	.415	.415	NONE	NONE	NONE	425	350
		STAGE # 1	0	NONE	---	0					
		STAGE # 2	0	NONE	---	0					
		STAGE # 3	0	NONE	---	0					
GRILL CHICK-FLAT	YES	TURN IN	195	MANUAL	---	---	NONE	NONE	NONE	425	350
		REMOVE IN	410	AUTO	---	---					
FOLDED EGGS-FLAT	YES	REMOVE IN	35	AUTO	---	---	NONE	NONE	NONE	OFF	265
ROUND EGGS-FLAT	YES	REMOVE IN	150	AUTO	---	---	NONE	NONE	NONE	OFF	265
CHICK F BRD-FLAT	YES	REMOVE IN	100	AUTO	---	---	NONE	NONE	NONE	425	350

CONTROLLER MENU ITEMS (EPROM CHIP VER. 7.XX)

ITEM	ACTIVE	FUNCTION	TIME	ALARM	GAP (NON-MULTI)	GAP (MULTI)	MUST REMOVE TIME	TOAST BUNS TIME	TOAST BUNS ALARM	TOP TEMP (F)	BOTTOM TEMP (F)
10:1-FLAT	NO	SEAR IN	20	MANUAL	---	---	NONE	NONE	NONE	OFF	340
		TURN IN	75	AUTO	---	---					
		REMOVE IN	125	AUTO	---	---					
4:1-FLAT	NO	SEAR IN	20	MANUAL	---	---	NONE	NONE	NONE	OFF	365
		TURN IN	150	AUTO	---	---					
		REMOVE IN	270	AUTO	---	---					
McRIB-FLAT	NO	TURN IN	270	AUTO	---	---	NONE	NONE	NONE	OFF	365
SAUSAGE-FLAT FZN	NO	TURN/SEAR IN	150	MANUAL	---	---	NONE	NONE	NONE	OFF	365
		REMOVE IN	270	AUTO	---	---					
HOTCAKES-FLAT	YES	TURN IN	90	AUTO	---	---	NONE	NONE	NONE	OFF	365
		REMOVE IN	140	AUTO	---	---					
		REMOVE IN	0	AUTO	469	469					
OPT MENU 1-CLAM	NO	STAGE # 1	0	NONE	---	0	NONE	NONE	NONE	OFF	OFF
		STAGE # 2	0	NONE	---	0					
		STAGE # 3	0	NONE	---	0					
OPT MENU 2-CLAM THRU	NO	REMOVE IN	0	AUTO	.250	.250	NONE	NONE	NONE	OFF	OFF
		STAGE # 1	0	NONE	---	0					
		STAGE # 2	0	NONE	---	0					
OPT MENU 7-CLAM		STAGE # 3	0	NONE	---	0					
OPT MENU 1-FLAT THRU	NO	SEAR IN	0	AUTO	---	---	NONE	NONE	NONE	OFF	OFF
		TURN IN	0	AUTO	---	---					
		REMOVE IN	0	AUTO	---	---					
OPT MENU 4-FLAT		REMOVE IN	0	AUTO	---	---					
CLEAN MODE	YES(ONLY)	READY TO CLEAN	NONE	NONE	.090	.090	NONE	NONE	NONE	325	325

TEMPERATURE CONVERSION (F / C)

C	F	C	F	C	F	C	F	C	F
27	80	54	128	80	176	107	224	134	272
27	81	54	129	80	177	107	225	134	273
28	82	55	130	81	178	108	226	134	274
28	83	55	131	81	179	108	227	135	275
29	84	56	132	82	180	109	228	135	276
30	85	56	133	83	181	110	229	136	277
30	86	57	134	83	182	110	230	137	278
31	87	57	135	84	183	111	231	137	279
31	88	58	136	84	184	111	232	138	280
32	89	59	137	85	185	112	233	138	281
32	90	59	138	85	186	112	234	139	282
33	91	60	139	86	187	113	235	139	283
33	92	60	140	86	188	114	236	140	284
34	93	61	141	87	189	114	237	141	285
34	94	61	142	88	190	115	238	141	286
35	95	62	143	88	191	115	239	142	287
36	96	62	144	89	192	116	240	142	288
36	97	63	145	89	193	116	241	143	289
37	98	63	146	90	194	117	242	143	290
37	99	64	147	90	195	117	243	144	291
38	100	64	148	91	196	118	244	144	292
38	101	65	149	91	197	119	245	145	293
39	102	65	150	92	198	119	246	146	294
40	103	66	151	93	199	120	247	146	295
40	104	66	152	94	200	120	248	147	296
41	105	67	153	94	201	121	249	147	297
41	106	68	154	94	202	121	250	148	298
42	107	68	155	95	203	122	251	148	299
42	108	69	156	95	204	122	252	149	300
43	109	70	157	96	205	123	253	149	301
43	110	70	158	97	206	124	254	150	302
44	111	71	159	97	207	124	255	151	303
44	112	71	160	98	208	125	256	151	304
45	113	72	161	98	209	125	257	152	305
45	114	72	162	99	210	126	258	152	306
46	115	73	163	99	211	126	259	153	307
46	116	74	164	100	212	127	260	153	308
47	117	74	165	101	213	127	261	154	309
48	118	75	166	101	214	128	262	154	310
48	119	75	167	102	215	128	263	155	311
49	120	76	168	102	216	129	264	156	312
49	121	76	169	103	217	130	265	156	313
50	122	77	170	103	218	130	266	157	314
50	123	77	171	104	219	130	267	157	315
51	124	78	172	105	220	131	268	158	316
52	125	78	173	105	221	131	269	158	317
52	126	79	174	106	222	132	270	159	318
53	127	79	175	106	223	133	271	159	319

TEMPERATURE CONVERSION (F / C)

C	F	C	F	C	F	C	F	C	F
160	320	187	368	213	416	240	464	267	512
161	321	187	369	214	417	241	465	267	513
161	322	188	370	214	418	241	466	268	514
162	323	188	371	215	419	242	467	268	515
162	324	189	372	216	420	242	468	269	516
163	325	189	373	216	421	243	469	269	517
163	326	190	374	217	422	243	470	270	518
164	327	191	375	217	423	244	471	271	519
164	328	191	376	218	424	244	472	271	520
165	329	192	377	218	425	245	473	272	521
166	330	192	378	219	426	246	474	272	522
166	331	193	379	219	427	246	475	273	523
167	332	193	380	220	428	247	476	273	524
167	333	194	381	221	429	247	477	274	525
168	334	194	382	221	430	248	478	274	526
168	335	195	383	222	431	248	479	275	527
169	336	196	384	222	432	249	480	276	528
169	337	196	385	223	433	249	481	276	529
170	338	197	386	223	434	250	482	277	530
171	339	197	387	224	435	241	483	277	531
171	340	198	388	224	436	241	484	278	532
172	341	198	389	225	437	252	485	278	533
172	342	199	390	226	438	252	486	279	534
173	343	199	391	226	439	253	487	279	535
173	344	200	392	227	440	253	488	280	536
174	345	201	393	227	441	254	489	281	537
174	346	201	394	228	442	254	490	281	538
175	347	202	395	228	443	255	491	282	539
176	348	202	396	229	444	256	492	282	540
176	349	203	397	229	445	256	493	283	541
177	350	203	398	230	446	257	494	283	542
177	351	204	399	231	447	257	495	284	543
178	352	204	400	231	448	258	496	284	544
178	353	205	401	232	449	258	497	285	545
179	354	206	402	232	450	259	498	285	546
179	355	206	403	233	451	259	499	286	547
180	356	207	404	233	452	260	500	287	548
181	357	207	405	234	453	261	501	287	549
181	358	208	406	234	454	261	502	288	550
182	359	208	407	235	455	262	503	288	551
182	360	209	408	236	456	262	504	289	552
183	361	209	409	236	457	263	505	290	553
183	362	210	410	237	458	263	506	290	554
184	363	211	411	237	459	264	507	291	555
184	364	211	412	238	460	264	508	291	556
185	365	212	413	238	461	265	509	292	557
186	366	212	414	239	462	266	510	292	558
186	367	213	415	239	463	266	511	293	559

NOTES

A series of horizontal lines for writing notes, consisting of approximately 30 lines with alternating line thicknesses.

MANUAL CORRECTIONS AND MODIFICATIONS

While every effort has been made to ensure that the information contained in this manual provided to you is updated, and contains accurate information, if you believe that an error has been made, or simply would like to suggest modifications, or improvements, please fill in the information below and fax it to 570-636-9874 or mail it to the address below. A review of any received forms will be considered on a regular basis.

Name _____

Address _____

City _____ State _____ Zip _____

Page Number in which error exists _____

Description of Error _____

Suggestions or improvements to this manual: _____

Fax to 570-636-9874

- or -

Mail to:

**Garland Commercial Industries
McDonalds Sale / Service Account
185 East South Street
Freeland, PA 18224**

Thank you for your continued support!
Garland P/N Rev 3 P/N 1881060 IN(021605)

